

Screw jacks MA Series

Screw jacks MA Series with travelling screw (Mod.A) STRUCTURAL ELEMENTS

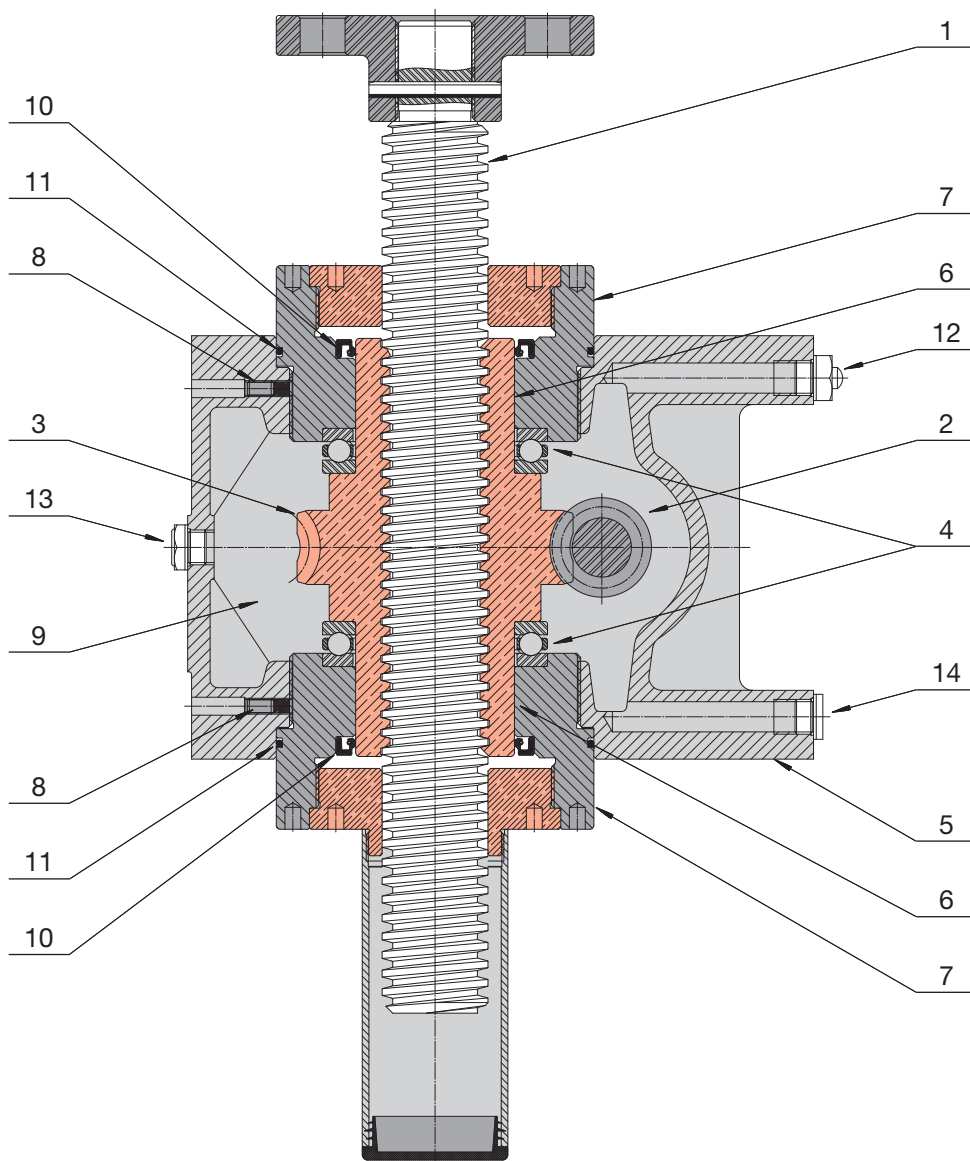

- 1 - acme screw in steel C 43 (UNI 7847), whirled thread
- 2 - worm shaft with true involute, ground worm profile ZI (UNI 4760), made in steel, case-hardened
- 3 - bronze wormwheel with true involute profile ZI (UNI 4760), the length of the internal nut is double respect to SJ Series; the bigger mass of the bronze nut allows a higher duty cycle and a longer life
- 4 - thrust ball bearing for high load capacity
- 5 - gear box shape which allows effective heat dissipation giving increased duty cycle
- 6 - radial guide of the wormwheel for increased stiffness and improved efficiency
- 7 - raised cover with bronze guide against radial load for acme screw; the raised cover may also be used as a spigot diameter
- 8 - grub screw which prevents the threaded cover unscrewing
- 9 - synthetic oil lubricated worm gearbox for a better heat dissipation; this allows higher input speed, improved efficiency and longer life
- 10 - radial lubricant seal
- 11 - O-Ring as lubricant seal
- 12 - breather
- 13 - oil level plug
- 14 - oil drain plug

Screw jacks MA Series

Screw jacks MA Series with travelling nut (Mod.B) STRUCTURAL ELEMENTS

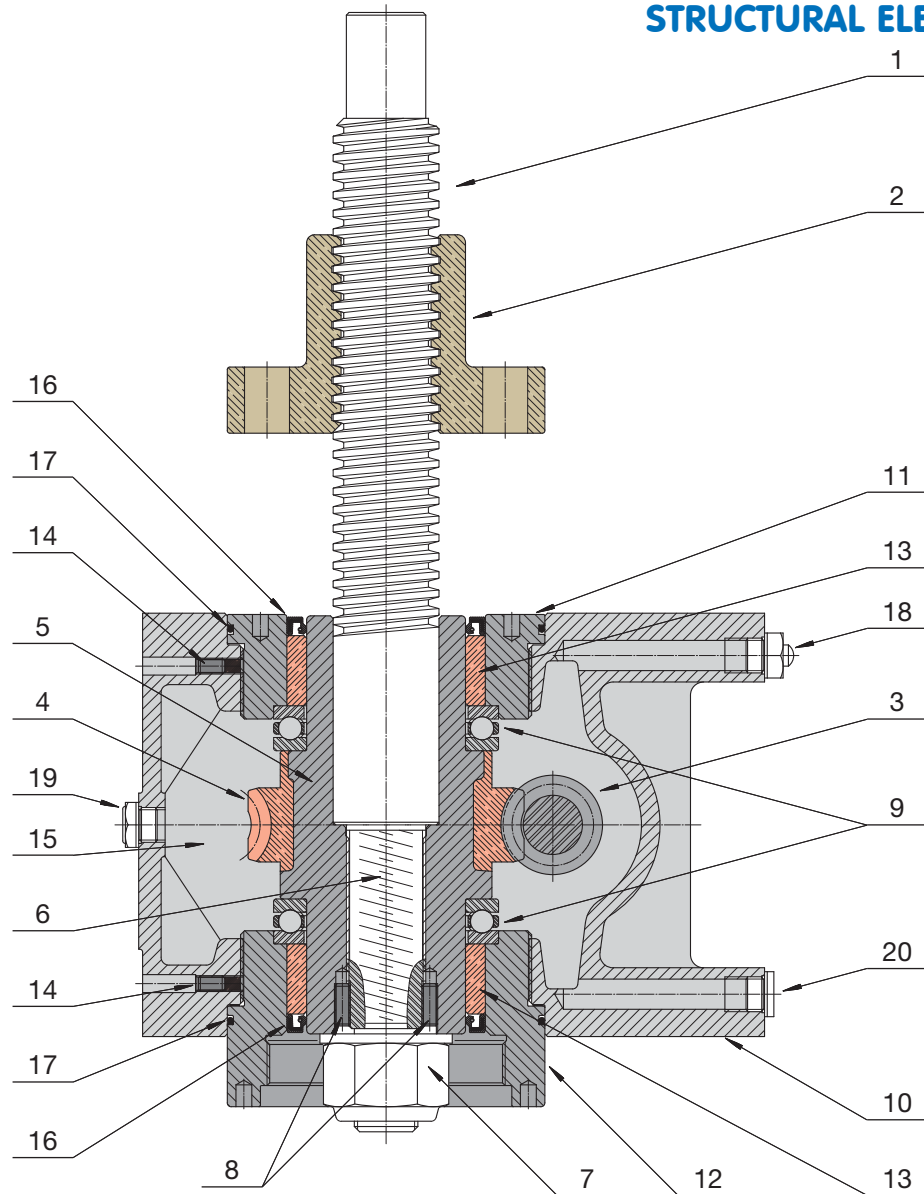

2

- 1 - acme screw in steel C 43 (UNI 7847), whirled thread
- 2 - bronze travelling nut with flange
- 3 - worm shaft with true involute, ground worm profile ZI (UNI 4760), made in steel, case-hardened
- 4 - bronze wormwheel with true involute profile ZI (UNI 4760)
- 5 - cast iron support of the wormwheel bronze rim
- 6 - acme screw fixed to the wormwheel through the cylindrical centring part and LEFT-HAND (for push load) or RIGHT-HAND (for pull load) metric thread
- 7 - lock nut with the opposite direction metric thread to ensure safe acme screw fixing
- 8 - acme screw – wormwheel pins against unscrewing
- 9 - thrust ball bearing for high load capacity
- 10 - gear box
- 11 - low cover
- 12 - raised cover; may also be used as a spigot diameter
- 13 - radial bronze guide of the wormwheel, for increased stiffness and improved efficiency
- 14 - grub screw which prevents the threaded cover unscrewing
- 15 - synthetic oil lubricated worm gearbox
- 16 - radial lubricant seal
- 17 - O-Ring as lubricant seal
- 18 - breather
- 19 - oil level plug
- 20 - oil drain plug

Screw jacks MA Series

Screw jacks MA Series with 1-start acme screw TECHNICAL SPECIFICATIONS

SCREW JACK SIZE		MA 5	MA 10	MA 25	MA 50
Load capacity [kN], (push - pull)		5	10	25	50
1-start acme screw		Tr 18x4	Tr 22x5	Tr 30x6	Tr 40x7
Worm gear centre distance [mm]		30	40	50	63
Available ratio	RV	1 : 4 (4 : 16)	1 : 5 (4 : 20)	1 : 6 (4 : 24)	1 : 7 (4 : 28)
	RN	1 : 16 (2 : 32)	1 : 20	1 : 18 (2 : 36)	1 : 14 (2 : 28)
	RL	1 : 24	1 : 25	1 : 24	1 : 28
Stroke [mm] for 1 input shaft revolution	Ratio				
	RV1	1	1	1	1
	RN1	0.25	0.25	0.33	0.5
Starting efficiency	Ratio				
	RV1	0.21	0.22	0.20	0.18
	RN1	0.16	0.15	0.16	0.15
Running efficiency at 3000 rpm ⁽¹⁾	Ratio				
	RV1	0.40	0.41	0.38	0.37
	RN1	0.31	0.30	0.30	0.32
Starting torque on input shaft at max. load [Nm]	Ratio				
	RV1	3.8	7.2	19.9	44.1
	RN1	1.2	2.6	8.3	24.8
Max. permissible operating power [kW] ⁽²⁾	Ratio				
	RV1	0.40	0.60	1.2	2.4
	RN1	0.20	0.30	0.7	1.7
Reactive torque on acme screw (nut) required at max. load [Nm]	Ratio				
	RV1	0.40	0.60	1.2	2.4
	RN1	0.20	0.30	0.7	1.7
Gear box material	Ratio				
	RV1	0.40	0.60	1.2	2.4
	RN1	0.20	0.30	0.7	1.7
Reactive torque on acme screw (nut) required at max. load [Nm]		8	20	65	165
Gear box material		casting in aluminium alloy EN 1706 - AC-AISi10Mg T6		casting in spheroidal graphite iron EN-GJS-500-7 (UNI EN 1563)	
Mass of screw jack without acme screw [kg]		2.2	4.3	13	26
Mass for every 100 mm of acme screw [kg]		0.16	0.23	0.45	0.8

(1) - efficiency figures at different input speed on page 36

(2) - THERMAL limit, referred to following working conditions

duty cycle 40 % over 10 min time period (30 % over 1 hour time period) for screw jacks with travelling screw (Mod.A)

duty cycle 30 % over 10 min time period (20 % over 1 hour time period) for screw jacks with travelling nut (Mod.B)

at 25°C environment temperature

Screw jacks MA Series

Screw jacks MA Series with 1-start acme screw TECHNICAL SPECIFICATIONS

MA 80	MA 100	MA 200	MA 350	SCREW JACK SIZE		
80	100	200	350	Load capacity [kN], (push - pull)		
Tr 55x9	Tr 60x12	Tr 70x12	Tr 100x16	1-start acme screw		
63	80	100	125	Worm gear centre distance [mm]		
1 : 7 (4 : 28)	1 : 8 (4 : 32)	1 : 8 (4 : 32)	3 : 32	RV	Available ratio	
1 : 14 (2 : 28)	1 : 24	1 : 24	1 : 16 (2 : 32)	RN		
1 : 28	1 : 32	1 : 32	1 : 32	RL		
1.28	1.5	1.5	1.5	RV1	Ratio	Stroke [mm] for 1 input shaft revolution
0.64	0.5	0.5	1	RN1		
0.32	0.38	0.38	0.5	RL1		
0.18	0.20	0.17	0.16	RV1	Ratio	Starting efficiency
0.15	0.13	0.12	0.14	RN1		
0.11	0.12	0.11	0.10	RL1		
0.39	0.41	0.38	0.39	RV1	Ratio	Running efficiency at 3000 rpm ⁽¹⁾
0.33	0.32	0.31	0.34	RN1		
0.27	0.30	0.28	0.29	RL1		
77	120	282	525	RV1	Ratio	Starting torque on input shaft at max. load [Nm]
47	62	133	400	RN1		
34	50	109	280	RL1		
2.5	3.0	4.5	8.0	RV1	Ratio	Max. permissible operating power [kW] ⁽²⁾
1.8	2.6	4.0	7.0	RN1		
1.2	2.3	3.8	6.8	RL1		
368	525	1180	2880	Reactive torque on acme screw (nut) required at max. load [Nm]		
casting in spheroidal graphite iron EN-GJS-500-7 (UNI EN 1563)				Gear box material		
26	48	75	145	Mass of screw jack without acme screw [kg]		
1.6	1.8	2.5	5.2	Mass for every 100 mm of acme screw [kg]		

⁽¹⁾ - efficiency figures at different input speed on page 36

⁽²⁾ - THERMAL limit, referred to following working conditions

duty cycle 40 % over 10 min time period (30 % over 1 hour time period) for screw jacks with travelling screw (Mod.A)

duty cycle 30 % over 10 min time period (20 % over 1 hour time period) for screw jacks with travelling nut (Mod.B)

at 25°C environment temperature

Screw jacks MA Series - 1-start acme screw

Following tables show the screw jack LINEAR SPEED v [mm/s] and relative TORQUE T_1 [Nm] and POWER P_1 [kW] on input shaft, with reference to the INPUT SPEED n_1 [rpm], the RATIO (RV, RN, RL) and the LOAD [kN] applied on the screw jack.

Intermediate values for linear speed v , torque T_1 and power P_1 at different input speed can be calculated by linear interpolation of the figures stated in the table.

The figures in the tables refer to work at 25°C environment temperature and max. duty cycle of:

40 % over 10 min time period or 30 % over 1 hour time period, for screw jacks with travelling screw (Mod.A),

30 % over 10 min time period or 20 % over 1 hour time period, for screw jacks with travelling nut (Mod.B)

ATTENTION! The figures in the **red shaded area** indicate operational restrictions due to thermal limits. When the selection is made within such area, the duty cycle must be reduced or the greater size screw jack must be selected, in order to allow effective heat dissipation. For a better evaluation, please contact SERVOMECH Engineering Dpt.

2

MA 5				LOAD																							
				5 kN						4 kN						3 kN						1 kN					
				RV1		RN1		RL1		RV1		RN1		RL1		RV1		RN1		RL1		RV1		RN1		RL1	
n_1 [rpm]	LINEAR SPEED v [mm/s]			T_1 Nm	P_1 kW	T_1 Nm	P_1 kW	T_1 Nm	P_1 kW	T_1 Nm	P_1 kW	T_1 Nm	P_1 kW	T_1 Nm	P_1 kW	T_1 Nm	P_1 kW	T_1 Nm	P_1 kW	T_1 Nm	P_1 kW	T_1 Nm	P_1 kW	T_1 Nm	P_1 kW		
	RV1	RN1	RL1																								
3 000	50	12.5	8.3	2.0	0.63	0.7	0.20	0.5	0.15	1.6	0.50	0.5	0.16	0.4	0.12	1.2	0.38	0.4	0.12	0.3	0.09	0.4	0.13	0.1	0.04	0.1	0.03
1 500	25	6.3	4.2	2.2	0.35	0.7	0.11	0.5	0.08	1.8	0.28	0.6	0.09	0.4	0.07	1.3	0.21	0.4	0.07	0.3	0.05	0.4	0.07	0.1	0.02	0.1	0.02
1 000	16.7	4.2	2.8	2.3	0.24	0.7	0.08	0.6	0.06	1.9	0.20	0.6	0.06	0.4	0.05	1.4	0.15	0.4	0.05	0.3	0.03	0.5	0.05	0.1	0.01	0.1	0.01
750	12.5	3.1	2.1	2.4	0.19	0.7	0.05	0.6	0.05	1.9	0.15	0.6	0.05	0.5	0.04	1.4	0.11	0.4	0.04	0.3	0.03	0.5	0.04	0.1	0.01	0.1	0.01
500	8.3	2.1	1.4	2.5	0.13	0.8	0.04	0.6	0.03	2.0	0.11	0.6	0.03	0.5	0.03	1.5	0.08	0.5	0.02	0.4	0.02	0.5	0.03	0.1	0.01	0.1	0.01
300	5	1.3	0.8	2.6	0.08	0.8	0.03	0.7	0.02	2.1	0.07	0.7	0.02	0.5	0.02	1.6	0.05	0.5	0.02	0.4	0.01	0.5	0.02	0.2	0.01	0.1	0.01
100	1.7	0.4	0.3	2.8	0.03	0.9	0.01	0.8	0.01	2.2	0.02	0.7	0.01	0.6	0.01	1.7	0.02	0.5	0.01	0.5	0.01	0.6	0.01	0.2	0.01	0.1	0.01

MA 10				LOAD																							
				10 kN						8 kN						6 kN						2 kN					
				RV1		RN1		RL1		RV1		RN1		RL1		RV1		RN1		RL1		RV1		RN1		RL1	
n_1 [rpm]	LINEAR SPEED v [mm/s]			T_1 Nm	P_1 kW	T_1 Nm	P_1 kW	T_1 Nm	P_1 kW	T_1 Nm	P_1 kW	T_1 Nm	P_1 kW	T_1 Nm	P_1 kW	T_1 Nm	P_1 kW	T_1 Nm	P_1 kW	T_1 Nm	P_1 kW	T_1 Nm	P_1 kW	T_1 Nm	P_1 kW	T_1 Nm	P_1 kW
	RV1	RN1	RL1																								
3 000	50	12.5	10	3.9	1.22	1.3	0.42	1.1	0.36	3.1	0.89	1.1	0.33	0.9	0.29	2.3	0.73	0.8	0.25	0.7	0.21	0.8	0.24	0.3	0.08	0.2	0.07
1 500	25	6.3	5	4.4	0.68	1.4	0.23	1.2	0.19	3.5	0.55	1.1	0.18	0.9	0.15	2.6	0.41	0.9	0.13	0.7	0.11	0.9	0.14	0.3	0.04	0.2	0.04
1 000	16.7	4.2	3.3	4.6	0.48	1.5	0.16	1.2	0.13	3.6	0.38	1.2	0.13	1.0	0.10	2.7	0.29	0.9	0.09	0.7	0.08	0.9	0.10	0.3	0.03	0.2	0.03
750	12.5	3.1	2.5	4.7	0.37	1.6	0.12	1.3	0.10	3.8	0.30	1.2	0.10	1.0	0.08	2.8	0.22	0.9	0.07	0.8	0.06	0.9	0.07	0.3	0.02	0.2	0.02
500	8.3	2.1	1.7	5.0	0.26	1.6	0.09	1.4	0.07	4.0	0.21	1.3	0.07	1.1	0.06	3.0	0.16	1.0	0.05	0.8	0.04	1.0	0.05	0.3	0.02	0.3	0.01
300	5	1.3	1	5.1	0.16	1.8	0.05	1.5	0.05	4.1	0.13	1.4	0.04	1.2	0.04	3.1	0.10	1.1	0.03	0.9	0.03	1.0	0.03	0.3	0.01	0.3	0.01
100	1.7	0.4	0.3	5.5	0.06	2.0	0.02	1.6	0.02	4.4	0.05	1.6	0.02	1.3	0.01	3.3	0.03	1.2	0.01	1.0	0.01	1.1	0.01	0.4	0.01	0.3	0.01

MA 25				LOAD																							
				25 kN						20 kN						15 kN						10 kN					
				RV1		RN1		RL1		RV1		RN1		RL1		RV1		RN1		RL1		RV1		RN1		RL1	
n_1 [rpm]	LINEAR SPEED v [mm/s]			T_1 Nm	P_1 kW	T_1 Nm	P_1 kW	T_1 Nm	P_1 kW	T_1 Nm	P_1 kW	T_1 Nm	P_1 kW	T_1 Nm	P_1 kW	T_1 Nm	P_1 kW	T_1 Nm	P_1 kW	T_1 Nm	P_1 kW	T_1 Nm	P_1 kW	T_1 Nm	P_1 kW	T_1 Nm	P_1 kW
	RV1	RN1	RL1																								
3 000	50	16.7	12.5			3.5	1.11	3.6	1.12	8.4	2.63	3.5	1.11	2.8	0.89	6.3	1.97	2.7	0.83	2.1	0.67	4.1	1.30	1.7	0.55	1.4	0.45
1 500	25	8.3	6.3	11.7	1.83	4.8	0.76	3.9	0.61	9.3	1.47	3.9	0.60	3.1	0.49	7.0	1.10	2.9	0.45	2.3	0.37	4.6	0.74	1.9	0.30	1.6	0.25
1 000	16.7	5.6	4.2	12.2	1.28	5.0	0.53	4.1	0.43	9.8	1.03	4.0	0.42	3.3	0.34	7.3	0.77	3.0	0.32	2.5	0.26	4.8	0.52	2.0	0.21	1.6	0.18
750	12.5	4.2	3.1	12.7	1.00	5.2	0.41	4.2	0.33	10.2	0.80	4.2	0.33	3.4	0.27	7.6	0.60	3.1	0.24	2.5	0.20	5.0	0.40	2.1	0.16	1.7	0.14
500	8.3	2.8	2.1	13.5	0.71	5.5	0.29	4.5	0.24	10.8	0.56	4.4	0.23	3.6	0.19	8.1	0.42	3.3	0.17	2.7	0.14	5.4	0.28	2.2	0.12	1.8	0.10
300	5	1.7	1.3	14.1	0.44	5.8	0.18	4.8	0.15	11.3	0.35	4.6	0.15	3.9	0.12	8.5	0.27	3.5	0.11	2.9	0.09	5.6	0.09	2.4	0.08	2.0	0.06
100	1.7	0.6	0.4	15.1	0.16	6.5	0.07	5.5	0.06	12.1	0.13	5.2	0.05	4.4	0.05	9.0	0.09	3.9	0.04	3.3	0.03	6.0	0.06	2.6	0.03	2.2	0.03

MA 50				LOAD																							
				50 kN						35 kN						25 kN						10 kN					
				RV1		RN1		RL1		RV1		RN1		RL1		RV1		RN1		RL1		RV1		RN1		RL1	
n_1 [rpm]	LINEAR SPEED v [mm/s]			T_1 Nm	P_1 kW	T_1 Nm	P_1 kW	T_1 Nm	P_1 kW	T_1 Nm	P_1 kW	T_1 Nm	P_1 kW	T_1 Nm	P_1 kW	T_1 Nm	P_1 kW	T_1 Nm	P_1 kW	T_1 Nm	P_1 kW	T_1 Nm	P_1 kW	T_1 Nm	P_1 kW	T_1 Nm	P_1 kW
	RV1	RN1	RL1																								
3 000	50	25	12.5			12.4	3.91	7.7	2.40	15.1	4.73	8.7	2.73	5.4	1.68	10.8	3.38	6.2	1.95	3.8	1.20	4.3	1.35	2.5	0.78	1.5	0.48
1 500	25	12.5	6.3	25.0	3.92	14.4	2.26	8.5	1.34	17.5	2.74	10.0	1.58	6.0	0.94	12.5	1.96	7.2	1.13	4.3	0.67	5.0	0.78	2.9	0.45	1.7	0.27
1 000	16.7	8.3	4.2	26.5	2.78	13.3	1.60	9.1	0.96	18.6	1.94	10.7	1.12	6.4	0.67	13.3	1.39	7.6	0.80	4.6	0.48	5.3	0.56	3.1	0.32	1.8	0.19
750	12.5	6.3	3.1	27.4	2.15	16.0	1.25	9.5	0.74	19.2	1.51	11.1	0.87	6.6	0.52	13.7	1.08	7.9	0.62	4.7	0.37	5.5	0.43	3.2	0.25	1.9	0.15
500	8.3	4.2	2.1	28.8	1.51	16.4	0.86	10.0	0.52	20.2	1.06	11.5	0.60	7.0	0.37	14.4	0.75	8.2	0.43	5.0	0.26	5.8	0.30	3.3	0.17	2.0	0.11
300	5	2.5	1.3	30.5	0.96	17.4	0.55	10.8	0.34	21.3	0.67	12.2	0.38	7.6	0.24	15.2	0.48	8.7	0.27	5.4	0.17	6.1	0.19	3.5	0.11	2.1	0.07
100	1.7	0.8	0.4	33.0	0.35	19.3	0.20	12.5	0.13	23.1	0.24	13.5	0.14	8.8	0.09	16.5	0.17	9.7	0.10	6.3	0.07	6.6	0.07	3.9	0.04	2.5	0.03

Screw jacks MA Series - 1-start acme screw

Following tables show the screw jack LINEAR SPEED v [mm/s] and relative TORQUE T_1 [Nm] and POWER P_1 [kW] on input shaft, with reference to the INPUT SPEED n_1 [rpm], the RATIO (RV, RN, RL) and the LOAD [kN] applied on the screw jack.

Intermediate values for linear speed v , torque T_1 and power P_1 at different input speed can be calculated by linear interpolation of the figures stated in the table.

The figures in the tables refer to work at 25°C environment temperature and max. duty cycle of:

40 % over 10 min time period or 30 % over 1 hour time period, for screw jacks with travelling screw (Mod.A),

30 % over 10 min time period or 20 % over 1 hour time period, for screw jacks with travelling nut (Mod.B)

ATTENTION! The figures in the **red shaded area** indicate operational restrictions due to thermal limits. When the selection is made within such area, the duty cycle must be reduced or the greater size screw jack must be selected, in order to allow effective heat dissipation. For a better evaluation, please contact SERVOMECH Engineering Dpt.

MA 80				LOAD																							
				80 kN				60 kN				40 kN				20 kN											
				RATIO		RATIO		RATIO		RATIO		RATIO		RATIO		RATIO		RATIO									
n_1 [rpm]	LINEAR SPEED v [mm/s]			RV1	RN1	RL1	RV1	RN1	RL1	RV1	RN1	RL1	RV1	RN1	RL1	RV1	RN1	RL1									
	RV1	RN1	RL1	T_1 Nm	P_1 kW	T_1 Nm	P_1 kW	T_1 Nm	P_1 kW	T_1 Nm	P_1 kW	T_1 Nm	P_1 kW	T_1 Nm	P_1 kW	T_1 Nm	P_1 kW	T_1 Nm	P_1 kW	T_1 Nm	P_1 kW						
3 000	64.3	32.1	16.1													12.7	4.00	7.6	2.39	10.6	3.33	6.4	2.00	3.8	1.20		
1 500	32.0	16.0	8.0				18.0	2.83	36.7	5.76	21.5	3.37	13.5	2.12	24.5	3.84	14.3	2.25	9.0	1.41	12.2	1.92	7.2	1.12	4.5	0.71	
1 000	21.4	10.7	5.3	52.6	5.51	31.3	3.28	20.0	2.09	39.5	4.13	23.5	2.46	15.0	1.57	26.3	2.76	15.7	1.64	10.0	1.05	13.2	1.38	7.8	0.82	5.0	0.52
750	16.1	8.0	4.0	54.7	4.30	33.8	2.65	21.0	1.65	41.0	3.22	25.3	1.99	15.8	1.24	27.4	2.15	16.9	1.32	10.5	0.82	13.7	1.07	8.4	0.66	5.3	0.41
500	10.7	5.3	2.7	58.6	3.07	35.8	1.87	22.0	1.15	44.0	2.30	26.9	1.41	16.5	0.86	29.3	1.53	17.9	0.94	11.0	0.58	14.7	0.77	9.0	0.47	5.5	0.29
300	6.4	3.2	1.6	65.9	2.07	38.1	1.20	24.5	0.77	49.4	1.55	28.6	0.90	18.4	0.58	33.0	1.03	19.1	0.60	12.3	0.38	16.5	0.52	9.5	0.30	6.1	0.19
100	2.1	1.1	0.5	73.2	0.77	44.4	0.47	28.5	0.30	54.9	0.57	33.3	0.35	21.4	0.2	36.6	0.38	22.2	0.23	14.3	0.15	18.3	0.19	11.1	0.12	7.1	0.07

MA 100				LOAD																							
				100 kN				80 kN				50 kN				20 kN											
				RATIO		RATIO		RATIO		RATIO		RATIO		RATIO		RATIO		RATIO									
n_1 [rpm]	LINEAR SPEED v [mm/s]			RV1	RN1	RL1	RV1	RN1	RL1	RV1	RN1	RL1	RV1	RN1	RL1	RV1	RN1	RL1									
	RV1	RN1	RL1	T_1 Nm	P_1 kW	T_1 Nm	P_1 kW	T_1 Nm	P_1 kW	T_1 Nm	P_1 kW	T_1 Nm	P_1 kW	T_1 Nm	P_1 kW	T_1 Nm	P_1 kW	T_1 Nm	P_1 kW	T_1 Nm	P_1 kW						
3 000	75	25	18.8													12.4	3.91	10.0	3.12	11.6	3.66	5.0	1.56	4.0	1.25		
1 500	37.5	12.5	9.4			28.2	4.43	22.5	3.54			22.6	3.55	18.0	2.83	33.2	5.22	14.1	2.22	11.3	1.77	13.3	2.09	5.6	0.89	4.5	0.71
1 000	25	8.3	6.3	70.8	7.42	30.0	3.14	24.1	2.52	56.7	5.93	24.0	2.52	19.2	2.02	35.4	3.71	15.0	1.57	12.0	1.26	14.2	1.48	6.0	0.63	4.8	0.50
750	18.8	6.3	4.7	73.5	5.77	31.3	2.46	25.3	1.99	58.8	4.61	25.1	1.97	20.2	1.59	36.7	2.88	15.7	1.23	12.6	0.99	14.7	1.15	6.3	0.49	5.0	0.40
500	12.5	4.2	3.1	77.0	4.03	32.9	1.72	26.6	1.39	61.6	3.23	26.3	1.38	21.3	1.12	38.5	2.02	16.4	0.86	13.5	0.70	15.4	0.81	6.6	0.34	5.3	0.28
300	7.5	2.5	1.9	82.3	2.59	35.2	1.11	28.7	0.90	65.9	2.07	28.2	0.88	22.9	0.72	41.2	1.29	17.6	0.55	14.3	0.45	16.5	0.52	7.0	0.22	5.7	0.18
100	2.5	0.8	0.6	89.1	0.93	40.0	0.42	33.0	0.34	71.3	0.75	32.0	0.33	26.4	0.28	44.5	0.47	20.0	0.21	16.5	0.17	17.8	0.19	8.0	0.08	6.6	0.07

MA 200				LOAD																							
				200 kN				150 kN				100 kN				50 kN											
				RATIO		RATIO		RATIO		RATIO		RATIO		RATIO		RATIO		RATIO									
n_1 [rpm]	LINEAR SPEED v [mm/s]			RV1	RN1	RL1	RV1	RN1	RL1	RV1	RN1	RL1	RV1	RN1	RL1												
	RV1	RN1	RL1	T_1 Nm	P_1 kW	T_1 Nm	P_1 kW	T_1 Nm	P_1 kW	T_1 Nm	P_1 kW	T_1 Nm	P_1 kW	T_1 Nm	P_1 kW	T_1 Nm	P_1 kW										
3 000	75	25	18.8													25.7	8.06	21.3	6.70			12.8	4.03	10.7	3.35		
1 500	37.5	12.5	9.4			48.9	7.68			45.4	7.13	36.7	5.76			30.3	4.75	24.5	3.84	36.1	5.66	15.1	2.38	12.2	1.92		
1 000	25	8.3	6.3			65.0	6.80	52.1	5.48			48.7	5.10	39.1	4.09	76.5	8.01	32.5	3.40	26.1	2.73	38.8	4.01	16.2	1.70	13.0	1.36
750	18.8	6.3	4.7			68.6	5.39	52.8	4.30	119	9.37	51.4	4.04	41.1	3.22	79.6	6.25	34.3	2.69	27.4	2.15	39.8	3.12	17.1	1.35	13.7	1.07
500	12.5	4.2	3.1	167	8.77	71.4	3.74	57.7	3.02	125	6.58	53.5	2.80	43.2	2.26	83.8	4.39	35.7	1.87	28.8	1.51	41.9	2.19	17.8	0.93	14.4	0.75
300	7.5	2.5	1.9	178	5.62	76.1	2.39	61.8	1.94	134	4.21	57.1	1.79	46.4	1.46	89.4	2.81	38.1	1.20	30.9	0.97	44.7	1.40	19.0	0.60	15.5	0.49
100	2.5	0.8	0.6	195	2.05	87.3	0.92	71.3	0.76	146	1.54	65.9	0.69	54.3	0.57	97.8	1.02	44.0	0.46	36.2	0.38	48.9	0.51	22.0	0.23	18.1	0.19

MA 350				LOAD																							
				350 kN				250 kN				150 kN				100 kN											
				RATIO		RATIO		RATIO		RATIO		RATIO		RATIO		RATIO		RATIO									
n_1 [rpm]	LINEAR SPEED v [mm/s]			RV1	RN1	RL1	RV1	RN1	RL1	RV1	RN1	RL1	RV1	RN1	RL1												
	RV1	RN1	RL1	T_1 Nm	P_1 kW	T_1 Nm	P_1 kW	T_1 Nm	P_1 kW	T_1 Nm	P_1 kW	T_1 Nm	P_1 kW	T_1 Nm	P_1 kW	T_1 Nm	P_1 kW										
3 000	75	50	25													41.2	12.9	61.2	19.2	46.8	14.7	27.5	8.62				
1 500	37.5	25	12.5									80.9	12.7	113	17.8	82.0	12.8	48.5	7.62	75.5	11.8	54.7	8.59	32.3	5.08		
1 000	25	16.7	8.3					120	12.6			144	15.1	86.1	9.02	120	12.6	86.5	9.00	51.7	5.41	80.4	8.42	57.7	6.04	34.4	3.61
750	18.8	12.5	6.3			210	16.5	127	9.99	209	16.4	150	11.7	90.8	7.13	125	9.87	90.1	7.07	54.5	4.28	83.8	6.58	60.1	4.72	36.3	2.85
500	12.5	8.3	4.2	308	16.1	223	11.7	134	7.04	220	11.5	159	8.37	96.1	5.03	132	6.92	95.9	5.02	57.7	3.02	88.1	4.61	63.9	3.35	38.4	2.01
300	7.5	5	2.5	331	10.4	242	7.61	144	4.53	236	7.44	173	5.43	103	3.24	142	4.46	103	3.26	61.8	1.94	94.7	2.98	69.2	2.17	41.2	1.29
100	2.5	1.7	0.8	369	3.87	269	2.82	166	1.75	264	2.76	192	2.01	119	1.25	158	1.66	115	1.21	71.5	0.75	105	1.11	76.9	0.80	47.6	0.50

Screw jacks MA Series

Screw jacks MA Series with 2-starts acme screw TECHNICAL SPECIFICATIONS

SCREW JACK SIZE		MA 5	MA 10	MA 25	MA 50
Load capacity [kN], (push - pull)		5	10	25	50
2-starts acme screw		Tr 18x8 (P4)	Tr 22x10 (P5)	Tr 30x12 (P6)	Tr 40x14 (P7)
Worm gear centre distance [mm]		30	40	50	63
Available ratio	RV	1 : 4 (4 : 16)	1 : 5 (4 : 20)	1 : 6 (4 : 24)	1 : 7 (4 : 28)
	RN	1 : 16 (2 : 32)	1 : 20	1 : 18 (2 : 36)	1 : 14 (2 : 28)
	RL	1 : 24	1 : 25	1 : 24	1 : 28
Stroke [mm] for 1 input shaft revolution	Ratio				
	RV1	2	2	2	2
	RN1	0.50	0.50	0.67	1
Starting efficiency	Ratio				
	RV1	0.32	0.33	0.31	0.29
	RN1	0.25	0.22	0.23	0.24
Running efficiency at 3000 rpm ⁽¹⁾	Ratio				
	RV1	0.52	0.53	0.51	0.50
	RN1	0.41	0.40	0.43	0.44
Starting torque on input shaft at max. load [Nm]	Ratio				
	RV1	4.9	9.7	26	56
	RN1	1.6	3.6	12	34
Max. permissible operating power [kW] ⁽²⁾	Ratio				
	RV1	0.52	0.78	1.2	2.4
	RN1	0.26	0.40	0.7	1.7
Reactive torque on acme screw (nut) required at max. load [Nm]	Ratio				
	RV1	0.52	0.78	1.2	2.4
	RN1	0.26	0.40	0.7	1.7
Gear box material	Ratio				
	RV1	0.52	0.78	1.2	2.4
	RN1	0.26	0.40	0.7	1.7
Mass of screw jack without acme screw [kg]		2.2	4.3	13	26
Mass for every 100 mm of acme screw [kg]		0.16	0.23	0.45	0.8

(1) - efficiency figures at different input speed on page 36

(2) - THERMAL limit, referred to following working conditions

duty cycle 40 % over 10 min time period (30 % over 1 hour time period) for screw jacks with travelling screw (Mod.A)

duty cycle 30 % over 10 min time period (20 % over 1 hour time period) for screw jacks with travelling nut (Mod.B)

at 25°C environment temperature

Screw jacks MA Series

Screw jacks MA Series with 2-starts acme screw TECHNICAL SPECIFICATIONS

MA 80	MA 100	MA 200	MA 350	SCREW JACK SIZE		
80	100	200	350	Load capacity [kN], (push - pull)		
Tr 55x18 (P9)	Tr 60x24 (P12)	Tr 70x24 (P12)	Tr 100x32 (P16)	2-starts acme screw		
63	80	100	125	Worm gear centre distance [mm]		
1 : 7 (4 : 28)	1 : 8 (4 : 32)	1 : 8 (4 : 32)	3 : 32	RV	Available ratio	
1 : 14 (2 : 28)	1 : 24	1 : 24	1 : 16 (2 : 32)	RN		
1 : 28	1 : 32	1 : 32	1 : 32	RL		
2.57	3	3	3	RV1	Ratio	Stroke [mm] for 1 input shaft revolution
1.29	1	1	2	RN1		
0.64	0.75	0.75	1	RL1		
0.28	0.30	0.28	0.26	RV1	Ratio	Starting efficiency
0.23	0.21	0.20	0.23	RN1		
0.17	0.19	0.18	0.18	RL1		
0.51	0.54	0.52	0.51	RV1	Ratio	Running efficiency at 3000 rpm ⁽¹⁾
0.44	0.43	0.42	0.48	RN1		
0.38	0.41	0.39	0.41	RL1		
119	158	342	650	RV1	Ratio	Starting torque on input shaft at max. load [Nm]
72	76	163	480	RN1		
48	63	134	316	RL1		
3.2	4	6.2	10.5	RV1	Ratio	Max. permissible operating power [kW] ⁽²⁾
2.4	3.5	5.4	10	RN1		
1.7	3.1	5.3	9.6	RL1		
520	775	1 690	4 100	Reactive torque on acme screw (nut) required at max. load [Nm]		
casting in spheroidal graphite iron EN-GJS-500-7 (UNI EN 1563)				Gear box material		
26	48	75	145	Mass of screw jack without acme screw [kg]		
1.6	1.8	2.5	5.2	Mass for every 100 mm of acme screw [kg]		

⁽¹⁾ - efficiency figures at different input speed on page 36

⁽²⁾ - THERMAL limit, referred to following working conditions

duty cycle 40 % over 10 min time period (30 % over 1 hour time period) for screw jacks with travelling screw (Mod.A)

duty cycle 30 % over 10 min time period (20 % over 1 hour time period) for screw jacks with travelling nut (Mod.B)

at 25°C environment temperature

Screw jacks MA Series - 2-starts acme screw

Following tables show the screw jack LINEAR SPEED v [mm/s] and relative TORQUE T_1 [Nm] and POWER P_1 [kW] on input shaft, with reference to the INPUT SPEED n_1 [rpm], the RATIO (RV, RN, RL) and the LOAD [kN] applied on the screw jack.

Intermediate values for linear speed v , torque T_1 and power P_1 at different input speed can be calculated by linear interpolation of the figures stated in the table.

The figures in the tables refer to work at 25°C environment temperature and max. duty cycle of:

40 % over 10 min time period or 30 % over 1 hour time period, for screw jacks with travelling screw (Mod.A),

30 % over 10 min time period or 20 % over 1 hour time period, for screw jacks with travelling nut (Mod.B)

ATTENTION! The figures in the **red shaded area** indicate operational restrictions due to thermal limits. When the selection is made within such area, the duty cycle must be reduced or the greater size screw jack must be selected, in order to allow effective heat dissipation. For a better evaluation, please contact SERVOMECH Engineering Dpt.

MA 5				LOAD																							
				5 kN						4 kN						3 kN						1 kN					
n_1 [rpm]	LINEAR SPEED v [mm/s]			RATIO						RATIO						RATIO						RATIO					
	RV2	RN2	RL2	RV2		RN2		RL2		RV2		RN2		RL2		RV2		RN2		RL2		RV2		RN2		RL2	
				T_1 Nm	P_1 kW	T_1 Nm	P_1 kW	T_1 Nm	P_1 kW	T_1 Nm	P_1 kW	T_1 Nm	P_1 kW	T_1 Nm	P_1 kW	T_1 Nm	P_1 kW	T_1 Nm	P_1 kW	T_1 Nm	P_1 kW	T_1 Nm	P_1 kW	T_1 Nm	P_1 kW	T_1 Nm	P_1 kW
3 000	100	25	16.7	3.1	0.96	1.0	0.30	0.8	0.23	2.5	0.77	0.8	0.24	0.6	0.19	1.9	0.58	0.6	0.18	0.5	0.14	0.6	0.19	0.2	0.06	0.2	0.05
1 500	50	12.5	8.3	3.3	0.52	1.1	0.17	0.8	0.13	2.7	0.42	0.9	0.13	0.7	0.10	2.0	0.31	0.7	0.10	0.5	0.08	0.7	0.10	0.2	0.03	0.2	0.03
1 000	33.3	8.3	5.6	3.5	0.36	1.1	0.12	0.9	0.09	2.8	0.29	0.9	0.09	0.7	0.07	2.1	0.22	0.7	0.07	0.5	0.05	0.7	0.07	0.2	0.02	0.2	0.02
750	25	6.3	4.2	3.6	0.28	1.2	0.09	0.9	0.07	2.9	0.23	0.9	0.07	0.8	0.06	2.2	0.17	0.7	0.05	0.6	0.04	0.7	0.06	0.3	0.02	0.2	0.01
500	16.7	4.2	2.8	3.8	0.20	1.2	0.06	1.0	0.05	3.1	0.16	1.0	0.05	0.8	0.04	2.3	0.12	0.7	0.04	0.6	0.03	0.8	0.04	0.3	0.01	0.2	0.01
300	10	2.5	1.7	4.0	0.12	1.3	0.04	1.0	0.03	3.2	0.10	1.0	0.03	0.8	0.03	2.4	0.07	0.8	0.02	0.6	0.02	0.8	0.02	0.3	0.01	0.2	0.01
100	3.3	0.8	0.6	4.4	0.05	1.4	0.01	1.2	0.01	3.5	0.04	1.2	0.01	1.0	0.01	2.6	0.03	0.9	0.01	0.7	0.01	0.9	0.01	0.3	0.01	0.3	0.01

MA 10				LOAD																							
				10 kN						8 kN						6 kN						2 kN					
n_1 [rpm]	LINEAR SPEED v [mm/s]			RATIO						RATIO						RATIO						RATIO					
	RV2	RN2	RL2	RV2		RN2		RL2		RV2		RN2		RL2		RV2		RN2		RL2		RV2		RN2		RL2	
				T_1 Nm	P_1 kW	T_1 Nm	P_1 kW	T_1 Nm	P_1 kW	T_1 Nm	P_1 kW	T_1 Nm	P_1 kW	T_1 Nm	P_1 kW	T_1 Nm	P_1 kW	T_1 Nm	P_1 kW	T_1 Nm	P_1 kW	T_1 Nm	P_1 kW	T_1 Nm	P_1 kW	T_1 Nm	P_1 kW
3 000	100	25	20	6.1	1.90	2.0	0.62	1.7	0.52	4.9	1.52	1.6	0.49	1.3	0.41	3.7	1.14	1.2	0.37	1.0	0.31	1.2	0.38	0.4	0.12	0.4	0.10
1 500	50	12.5	10	6.6	1.03	2.2	0.34	1.9	0.29	5.3	0.82	1.8	0.27	1.5	0.23	4.0	0.62	1.3	0.21	1.1	0.17	1.3	0.21	0.5	0.07	0.4	0.05
1 000	33.3	8.3	6.7	6.9	0.72	2.3	0.24	1.9	0.20	5.5	0.57	1.9	0.19	1.6	0.16	4.1	0.43	1.4	0.14	1.2	0.12	1.4	0.14	0.5	0.05	0.4	0.04
750	25	6.3	5	7.2	0.56	2.4	0.19	2.1	0.16	5.8	0.45	1.9	0.15	1.6	0.13	4.3	0.34	1.5	0.11	1.2	0.10	1.5	0.11	0.5	0.04	0.4	0.03
500	16.7	4.2	3.3	7.5	0.39	2.6	0.13	2.2	0.11	6.0	0.31	2.1	0.11	1.7	0.09	5.5	0.24	1.6	0.08	1.3	0.07	1.5	0.08	0.5	0.03	0.5	0.02
300	10	2.5	2	7.8	0.24	2.8	0.09	2.3	0.07	6.2	0.19	2.2	0.07	1.9	0.06	4.7	0.15	1.7	0.05	1.4	0.04	1.6	0.05	0.6	0.02	0.5	0.01
100	3.3	0.8	0.7	8.6	0.09	3.2	0.03	2.7	0.03	6.9	0.07	2.5	0.03	2.2	0.02	5.2	0.05	1.9	0.02	1.6	0.02	1.7	0.02	0.7	0.01	0.6	0.01

MA 25				LOAD																							
				25 kN						20 kN						15 kN						10 kN					
n_1 [rpm]	LINEAR SPEED v [mm/s]			RATIO						RATIO						RATIO						RATIO					
	RV2	RN2	RL2	RV2		RN2		RL2		RV2		RN2		RL2		RV2		RN2		RL2		RV2		RN2		RL2	
				T_1 Nm	P_1 kW	T_1 Nm	P_1 kW	T_1 Nm	P_1 kW	T_1 Nm	P_1 kW	T_1 Nm	P_1 kW	T_1 Nm	P_1 kW	T_1 Nm	P_1 kW	T_1 Nm	P_1 kW	T_1 Nm	P_1 kW	T_1 Nm	P_1 kW	T_1 Nm	P_1 kW	T_1 Nm	P_1 kW
3 000	100	33.3	25	17.0	2.66	7.0	1.10	5.8	0.91	13.6	2.13	5.0	1.56	4.1	1.29	9.4	2.94	3.8	1.17	3.1	0.97	6.3	1.96	2.5	0.78	2.1	0.65
1 500	50	16.7	12.5	17.7	1.85	7.4	0.78	6.1	0.64	14.2	1.48	6.0	0.62	4.9	0.51	10.2	1.60	4.2	0.66	3.5	0.55	6.8	1.07	2.8	0.44	2.3	0.36
1 000	33.3	11.1	8.3	18.2	1.43	7.7	0.60	6.3	0.49	14.6	1.14	6.1	0.48	5.1	0.39	10.9	0.86	4.6	0.36	3.8	0.30	7.3	0.57	3.1	0.24	2.5	0.25
750	25	8.3	6.3	18.2	1.43	7.7	0.60	6.3	0.49	14.6	1.14	6.1	0.48	5.1	0.39	10.9	0.86	4.6	0.36	3.8	0.30	7.3	0.57	3.1	0.24	2.5	0.25
500	16.7	5.6	4.2	19.5	1.02	8.1	0.42	6.8	0.35	15.6	0.82	6.5	0.34	5.4	0.28	11.7	0.61	4.9	0.25	4.1	0.21	7.8	0.41	3.2	0.17	2.7	0.14
300	10	3.3	2.5	20.5	0.64	8.6	0.27	7.3	0.23	16.4	0.52	6.9	0.22	5.8	0.18	12.3	0.39	5.2	0.16	4.4	0.14	8.2	0.26	3.4	0.11	2.9	0.09
100	3.3	1.1	0.8	22.6	0.24	9.8	0.10	8.5	0.09	18.6	0.19	7.8	0.08	6.8	0.07	13.5	0.14	5.9	0.06	5.1	0.05	9.1	0.09	3.9	0.04	3.4	0.04

MA 50				LOAD																							
				50 kN						35 kN						25 kN						10 kN					
n_1 [rpm]	LINEAR SPEED v [mm/s]			RATIO						RATIO						RATIO						RATIO					
	RV2	RN2	RL2	RV2		RN2		RL2		RV2		RN2		RL2		RV2		RN2		RL2		RV2		RN2		RL2	
				T_1 Nm	P_1 kW	T_1 Nm	P_1 kW	T_1 Nm	P_1 kW	T_1 Nm	P_1 kW	T_1 Nm	P_1 kW	T_1 Nm	P_1 kW	T_1 Nm	P_1 kW	T_1 Nm	P_1 kW	T_1 Nm	P_1 kW	T_1 Nm	P_1 kW	T_1 Nm	P_1 kW	T_1 Nm	P_1 kW
3 000	100	50	25									12.6	3.95	7.4	2.33	16.0	5.00	9.0	2.82	5.3	1.7	6.4	2.00	3.6	1.13	2.1	0.67
1 500	50	25	12.5	34.8	5.46	20.1	3.15	12.1	1.91	24.3	3.82	14.1	2.21	8.5	1.33	17.4	2.73	10.0	1.58	6.1	0.95	7.0	1.09	4.0	0.63	2.5	0.38
1 000	33.3	16.7	8.3	37.1	3.88	21.3	2.23	13.1	1.37	26.0	2.72	14.9	1.56	9.2	0.96	18.5	1.94	10.6	1.11	6.6	0.69	7.4	0.78	4.3	0.45	2.6	0.27
750	25	12.5	6.3	38.2	3.00	22.6	1.77	13.5	1.06	26.7	2.10	15.8	1.24	9.5	0.74	19.1	1.50	11.3	0.89	6.7	0.53	7.7	0.60	4.5	0.35	2.7	0.21
500	16.7	8.3	4.2	40.6	2.13	23.5	1.23	14.4	0.75	28.4	1.49	16.4	0.86	10.1	0.53	20.3	1.06	11.7	0.61	7.2	0.38	8.1	0.43	4.7	0.25	2.9	0.15
300	10	5	2.5	43.3	1.36	24.8	0.78	15.8	0.49	30.3	0.95	17.3	0.54	11.0	0.35	21.6	0.68	12.4	0.39	7.9	0.25	8.7	0.27	5.0	0.16	3.2	0.10
100	3.3	1.7	0.8	46.7	0.49	28.0	0.29	18.2	0.19	32.7	0.34	19.6	0.20	12.7	0.13	23.3	0.24	14.0	0.15	9.1	0.10	9.4	0.10	5.6	0.06	3.7	0.04

Screw jacks MA Series - 2-starts acme screw

Following tables show the screw jack LINEAR SPEED v [mm/s] and relative TORQUE T_1 [Nm] and POWER P_1 [kW] on input shaft, with reference to the INPUT SPEED n_1 [rpm], the RATIO (RV, RN, RL) and the LOAD [kN] applied on the screw jack.

Intermediate values for linear speed v , torque T_1 and power P_1 at different input speed can be calculated by linear interpolation of the figures stated in the table.

The figures in the tables refer to work at 25°C environment temperature and max. duty cycle of:

40 % over 10 min time period or 30 % over 1 hour time period, for screw jacks with travelling screw (Mod.A),

30 % over 10 min time period or 20 % over 1 hour time period, for screw jacks with travelling nut (Mod.B)

ATTENTION! The figures in the **red shaded area** indicate operational restrictions due to thermal limits. When the selection is made within such area, the duty cycle must be reduced or the greater size screw jack must be selected, in order to allow effective heat dissipation. For a better evaluation, please contact SERVOMECH Engineering Dpt.

MA 80				LOAD																							
				80 kN				60 kN				40 kN				20 kN											
				RATIO		RATIO		RATIO		RATIO		RATIO		RATIO		RATIO		RATIO									
n_1 [rpm]	LINEAR SPEED v [mm/s]			RV2	RN2	RL2	RV2	RN2	RL2	RV2	RN2	RL2	RV2	RN2	RL2	RV2	RN2	RL2									
	RV2	RN2	RL2	T_1 Nm	P_1 kW	T_1 Nm	P_1 kW	T_1 Nm	P_1 kW	T_1 Nm	P_1 kW	T_1 Nm	P_1 kW	T_1 Nm	P_1 kW	T_1 Nm	P_1 kW	T_1 Nm	P_1 kW	T_1 Nm	P_1 kW						
3 000	129	64.3	32.1													18.6	5.84	10.9	3.42	16.2	5.07	9.3	2.92	5.5	1.71		
1 500	64.3	32.1	16.1				25.0	3.92			30.6	4.81	18.8	2.94	35.8	5.62	20.4	3.20	12.5	1.96	17.9	2.81	10.2	1.60	6.3	0.98	
1 000	42.9	21.4	10.7	76.2	7.98	43.9	4.59	27.4	2.87	57.2	5.98	32.9	3.46	20.6	2.15	38.1	3.99	22.0	2.30	13.7	1.43	19.1	1.99	11.0	1.15	6.9	0.72
750	32.1	16.1	8.0	78.1	6.13	46.7	3.67	28.6	2.24	58.5	4.60	35.0	2.75	21.5	1.68	39.0	3.06	23.4	1.83	14.3	1.12	19.5	1.53	11.7	0.92	7.2	0.56
500	21.4	10.7	5.4	82.3	4.31	49.1	2.57	30.0	1.57	61.8	3.23	36.8	1.93	22.5	1.18	41.2	2.15	24.6	1.28	15.0	0.78	20.6	1.08	12.3	0.68	7.5	0.39
300	12.9	6.4	3.2	90.5	2.84	51.9	1.63	33.0	1.03	67.9	2.13	38.9	1.22	24.7	0.78	45.3	1.42	25.9	0.81	16.5	0.52	22.7	0.71	13.0	0.41	8.3	0.26
100	4.3	2.1	1.1	98.9	1.03	59.3	0.62	37.9	0.40	74.1	0.78	44.5	0.47	28.4	0.30	49.4	0.52	29.7	0.31	19.0	0.20	24.7	0.26	14.8	0.16	9.5	0.10

MA 100				LOAD																							
				100 kN				80 kN				50 kN				20 kN											
				RATIO		RATIO		RATIO		RATIO		RATIO		RATIO		RATIO		RATIO									
n_1 [rpm]	LINEAR SPEED v [mm/s]			RV2	RN2	RL2	RV2	RN2	RL2	RV2	RN2	RL2	RV2	RN2	RL2	RV2	RN2	RL2									
	RV2	RN2	RL2	T_1 Nm	P_1 kW	T_1 Nm	P_1 kW	T_1 Nm	P_1 kW	T_1 Nm	P_1 kW	T_1 Nm	P_1 kW	T_1 Nm	P_1 kW	T_1 Nm	P_1 kW	T_1 Nm	P_1 kW	T_1 Nm	P_1 kW						
3 000	150	50	37.5									23.3	7.31			18.4	5.76	14.6	4.57	17.8	5.58	7.4	2.30	5.8	1.83		
1 500	75	25	18.8			40.8	6.40	33.2	5.20			32.6	5.12	26.5	4.16	48.6	7.63	20.4	3.20	16.6	2.60	19.4	3.05	8.2	1.28	6.7	1.04
1 000	50	16.7	12.5			44.6	4.67	36.1	3.78	82.3	8.62	35.7	3.73	28.9	3.02	51.5	5.39	22.3	2.33	18.1	1.89	20.6	2.16	8.9	0.93	7.2	0.76
750	37.5	12.5	9.4	106	8.32	46.6	3.66	36.8	2.89	84.8	6.66	37.3	2.93	29.5	2.31	53.0	4.16	23.3	1.83	18.4	1.44	21.2	1.66	9.3	0.73	7.4	0.58
500	25	8.3	6.3	112	5.87	48.3	2.53	38.9	2.04	89.7	4.69	38.6	2.02	31.2	1.63	56.0	2.93	24.1	1.26	19.5	1.02	22.4	1.17	9.7	0.51	7.8	0.41
300	15	5	3.8	121	3.80	52.2	1.64	43.4	1.36	96.9	3.04	41.7	1.31	34.8	1.09	60.5	1.90	26.1	0.82	21.7	0.68	24.2	0.76	10.5	0.33	8.7	0.27
100	5	1.7	1.3	131	1.37	59.5	0.62	50.0	0.52	105	1.10	47.6	0.50	40.0	0.42	65.4	0.69	29.8	0.31	25.0	0.26	26.2	0.27	11.9	0.12	10.0	0.10

MA 200				LOAD																							
				200 kN				150 kN				100 kN				50 kN											
				RATIO		RATIO		RATIO		RATIO		RATIO		RATIO		RATIO		RATIO									
n_1 [rpm]	LINEAR SPEED v [mm/s]			RV2	RN2	RL2	RV2	RN2	RL2	RV2	RN2	RL2	RV2	RN2	RL2												
	RV2	RN2	RL2	T_1 Nm	P_1 kW	T_1 Nm	P_1 kW	T_1 Nm	P_1 kW	T_1 Nm	P_1 kW	T_1 Nm	P_1 kW	T_1 Nm	P_1 kW	T_1 Nm	P_1 kW										
3 000	150	50	37.5												38.2	12.0	30.5	9.56	45.5	14.3	19.1	6.00	15.2	4.78			
1 500	75	25	18.8			84.2	13.3	67.8	10.7			63.2	9.92	50.9	7.99			42.1	6.61	33.9	5.32	50.3	7.89	21.1	3.31	17.0	2.66
1 000	50	16.7	12.5			90.5	9.48	74.3	7.77			67.9	7.11	55.7	5.83	107	11.2	45.3	4.74	37.1	3.89	53.5	5.61	22.6	2.37	18.6	1.94
750	37.5	12.5	9.4			96.6	7.58	78.1	6.13	166	13.0	72.4	5.69	58.6	4.60	110	8.66	48.3	3.79	39.1	3.07	55.1	4.33	24.2	1.90	19.5	1.53
500	25	8.3	6.3	235	12.3	103	5.38	81.8	4.28	177	9.23	77.1	4.04	61.4	3.21	118	6.15	51.4	2.69	40.9	2.14	58.8	3.08	25.7	1.35	20.5	1.07
300	15	5	3.8	254	7.98	110	3.45	90.1	2.83	191	5.99	82.5	2.59	67.6	2.12	127	3.99	55.0	1.73	45.0	1.41	63.5	2.00	27.5	0.86	22.5	0.71
100	5	1.7	1.3	279	2.92	127	1.33	103	1.08	210	2.19	95.1	1.00	77.3	0.81	140	1.46	63.4	0.66	51.6	0.54	69.7	0.73	31.7	0.33	25.8	0.27

MA 350				LOAD																								
				350 kN				250 kN				150 kN				100 kN												
				RATIO		RATIO		RATIO		RATIO		RATIO		RATIO		RATIO		RATIO										
n_1 [rpm]	LINEAR SPEED v [mm/s]			RV2	RN2	RL2	RV2	RN2	RL2	RV2	RN2	RL2	RV2	RN2	RL2													
	RV2	RN2	RL2	T_1 Nm	P_1 kW	T_1 Nm	P_1 kW	T_1 Nm	P_1 kW	T_1 Nm	P_1 kW	T_1 Nm	P_1 kW	T_1 Nm	P_1 kW	T_1 Nm	P_1 kW											
3 000	150	100	50																									
1 500	75	50	25													59.0	18.5											
1 000	50	33.3	16.7																									
750	37.5	25	12.5																									
500	25	16.7	8.3	423	22.2	315	16.5	191	9.98	302	15.8	225	11.8	136	7.13	181	9.49	135	7.06	81.7	4.28	121	6.32	89.9	4.70	54.5	2.85	
300	15	10	5	461	14.5	337	10.6	200	6.26	330	10.4	241	7.57	143	4.47	198	6.21	145	4.54	85.5	2.68	132	4.14	96.4	3.03	57.0	1.79	
100	5	3.3	1.7	496	5.19	381	4.0	242	2.53	354	3.70	272	2.85	173	1.81	212	2.22	163	1.71	104	1.08	142	1.48	109	1.14	69.0	0.72	

Screw jacks MA Series - overall dimensions

Model A - TRAVELLING SCREW

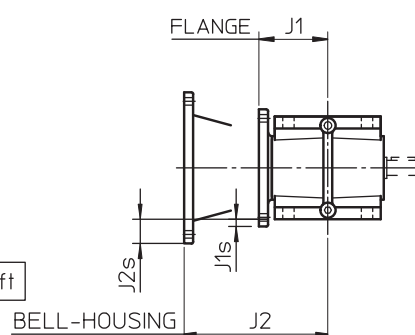
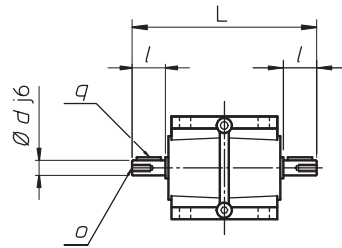
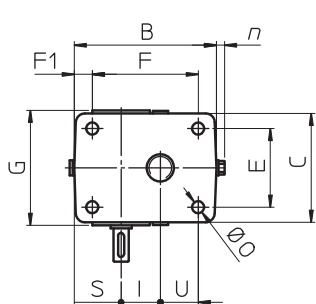
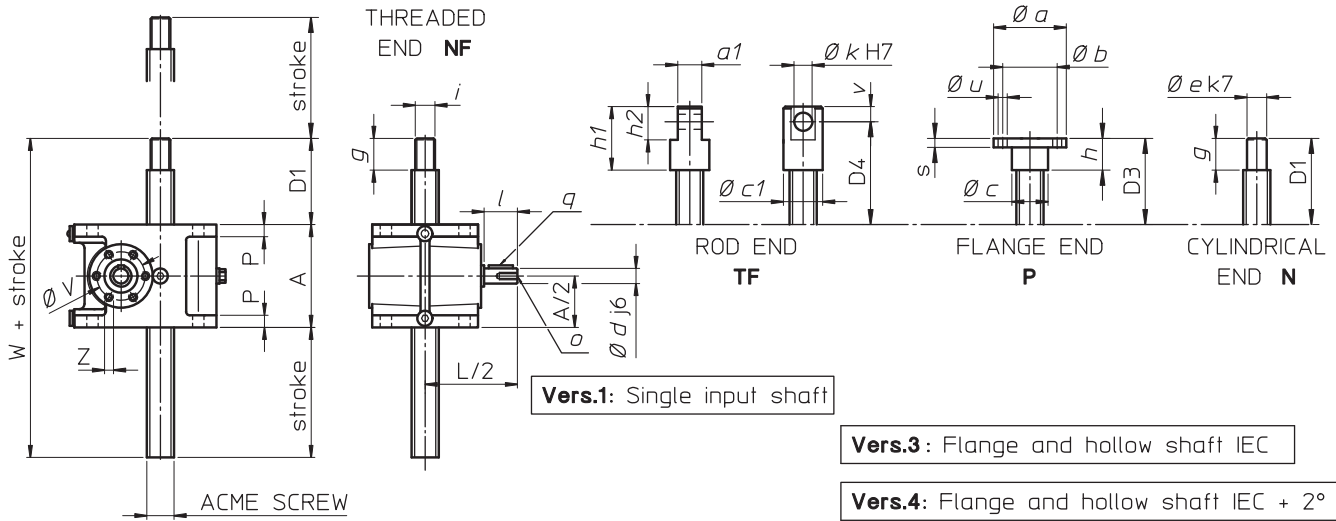

Vers.2: Double free input shaft

Vers.5: Vers.1 + bell-housing and coupling IEC

Vers.6: Vers.2 + bell-housing and coupling IEC

BRONZE GUIDES **G/TG**

PROTECTIVE TUBE **T**

PROTECTIVE TUBE **T**

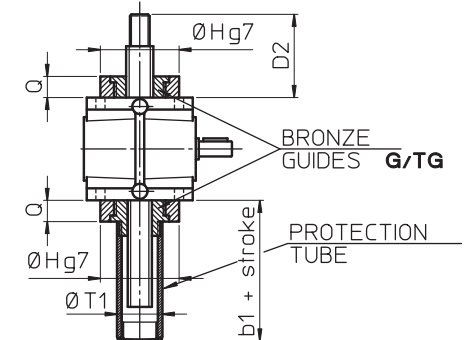
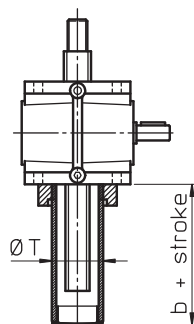

Model B - TRAVELLING NUT

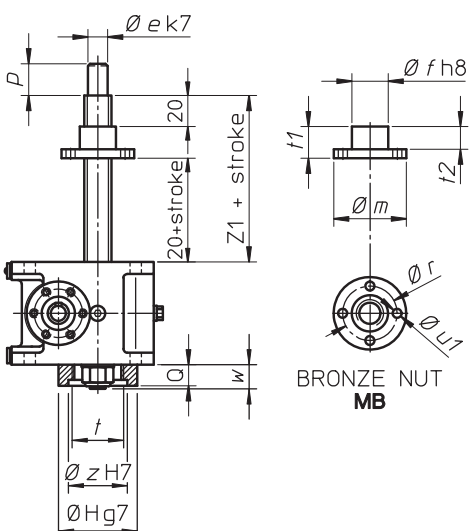

SIZE	MA 5	MA 10	MA 25	MA 50	MA 80	MA 100	MA 200	MA 350
ØT	50 (*)	55	70	90	90	110	150	180
b	exec. T	25	25	25	25	35	35	35
	exec. T + SN	75	75	105	105	105	115	135
	exec. T + AR	80	85	95	95	95	90	100
	exec. T + FCM	82	86	-	-	-	-	-
	exec. T + FCP	85	86	94	96	96	100	105
	exec. T+AR+FCP	90	96	115	117	117	115	120
ØT1	40 (*)	50 (*)	60 (*)	60 (*)	100 (*)	100 (*)	100 (*)	160
b1	exec. TG	50	51	59	61	61	65	90
	exec. TG + FCM	100	101	115	117	-	-	-
	exec. TG + FCP	100	101	109	111	111	115	140

* - for executions WITHOUT FCP: the actual value will be smaller

Screw jacks MA Series - overall dimensions

SIZE	MA 5	MA 10	MA 25	MA 50	MA 80	MA 100	MA 200	MA 350
ACME SCREW	Tr 18x4	Tr 22x 5	Tr 30x6	Tr 40x7	Tr 55x9	Tr 60x12	Tr 70x12	Tr 100x16
A	80	100	126	160	160	200	230	280
B	124	140	175	235	235	276	330	415
C	80	105	130	160	160	200	230	300
D1 (min.)	39	44	58	58	68	68	78	98
D2 (min.)	54	60	82	84	94	98	113	138
D3 (min.)	40	45	60	60	70	70	80	100
D4 (min.)	65	75	95	105	120	150	170	220
E	62	80	100	120	120	150	175	230
F	95	110	140	190	190	220	270	330
F1	12.5	14	17.5	23	23	26	30	42
G	100	114	136	165	165	205	256	326
∅ H	65	80	100	120	120	160	190	240
I	30	40	50	63	63	80	100	125
L	149	179	221.5	269	269	330	378	490
∅ O	9	9	13	17	17	21	28	34
P	10	12	15	19	19	22	26	30
Q	15	16	24	26	26	30	35	40
S	46.5	46	57.5	80	80	91	113	121
U	31	38	50	70	70	75	87	126
∅ V	42	46	64	63	63	74	110	118
W	119	144	184	218	228	268	308	378
Z	M5, depth 10	M5, depth 12	M5, depth 10	M6, depth 14	M6, depth 14	M6, depth 14	M10, depth 20	M10, depth 25
Z1	80	85	90	115	140	140	170	200
∅ a	68	75	100	120	150	150	180	250
a1	20	25	30	40	50	60	75	100
∅ b	45	55	75	85	110	110	130	180
∅ c	25	30	40	50	70	70	85	115
∅ c1	32	38	48	68	78	90	108	138
∅ d	10	14	19	24	24	28	32	38
∅ e	12	15	20	30	40	40	50	70
∅ f	30	40	50	60	75	80	100	150
g	19	24	38	38	48	48	58	78
h	20	25	40	40	50	50	60	80
h1	60	75	100	120	140	180	210	280
h2	30	40	50	70	80	100	120	160
i	M12x1.75	M16x1.5	M20x1.5	M30x2	M42x3	M42x3	M56x3	M80x3
∅ k	14	20	25	35	40	50	60	80
l	22	30	40	50	50	60	60	80
∅ m	68	75	100	120	130	150	180	250
n	—	—	10	10	10	12	10	10
o	M5, depth. 10	M6, depth 14	M8, depth 16	M8, depth 16	M8, depth 16	M8, depth 16	M10, depth 24	M12, depth 32
p	19	24	40	40	48	50	60	65
q	3x3x15	5x5x20	6x6x30	8x7x40	8x7x40	8x7x40	10x8x40	10x8x60
∅ r	50	56	75	90	105	120	140	200
s	8	10	12	15	20	20	25	35
t	M45x1.5	M55x1.5	M70x2	M90x2	M90x2	M110x2	M150x3	M180x3
t1	40	45	50	75	100	100	130	160
t2	28	33	35	50	80	70	95	115
∅ u, n° holes	∅ 7, 4 holes	∅ 9, 4 holes	∅ 11, 4 holes	∅ 17, 4 holes	∅ 21, 4 holes	∅ 21, 4 holes	∅ 26, 6 holes	∅ 30, 6 holes
∅ u1, n° holes	∅ 7, 4 holes	∅ 9, 4 holes	∅ 11, 4 holes	∅ 17, 4 holes	∅ 17, 4 holes	∅ 21, 4 holes	∅ 26, 6 holes	∅ 30, 6 holes
v	15	20	25	35	40	50	60	80
w	15	17	25	36	38	41	42	45
∅ z	50	60	77	95	95	120	160	200
J1	63 B5/B14: 62	63 B5/B14: 69	63/71 B5: 102	80 B5: 100	80 B5: 100	80/90 B5: 120	90 B5: 142 100/112 B5: 142	—
J1s	63 B5: 30 63 B14: 5	63 B5: 20 63 B14: —	63 B5: 7 71 B5: 17	80 B5: 20	80 B5: 20	80/90 B5: —	90 B5: — 100/112 B5: 10	—
J2	71 B5: 122 71 B14: 131	71 B5: 129 71 B14: 138	80 B5: 182 80 B14: 176 90 B5: 182 90 B14: 182	90 B5: 200 90 B14: 200 100 B5: 220 100 B14: 220	90 B5: 200 90 B14: 200 100/112 B5: 220 100/112 B14: 220	100/112 B5 240 100/112 B14: 240	132 B5: 297	132 B5: 353 160 B5: 365
J2s	71 B5: 40 71 B14: 12.5	71 B5: 30 71 B14: 3	80 B5: 37 80 B14: — 90 B5: 37 90 B14: 7	90 B5: 20 90 B14: — 100 B5: 45 100 B14: —	90 B5: 20 90 B14: — 100/112 B5: 45 100/112 B14: —	100/112 B5 25 100/112 B14: —	132 B5: 35	132 B5: 10 160 B5: 35

Screw jacks MA Series

Total efficiency of screw jack with 1-start acme screw

η	MA 5			MA 10			MA 25			MA 50			MA 80			MA 100			MA 200			MA 350					
	RATIO			RATIO			RATIO			RATIO			RATIO			RATIO			RATIO			RATIO					
n_1 [rpm]	RV1	RN1	RL1	RV1	RN1	RL1	RV1	RN1	RL1	RV1	RN1	RL1	RV1	RN1	RL1	RV1	RN1	RL1	RV1	RN1	RL1	RV1	RN1	RL1	RV1	RN1	RL1
3 000	0.40	0.31	0.27	0.41	0.30	0.28	0.38	0.30	0.28	0.37	0.32	0.26	0.39	0.33	0.27	0.41	0.32	0.30	0.38	0.31	0.28	0.39	0.34	0.29	0.39	0.34	0.29
1 500	0.36	0.28	0.25	0.37	0.28	0.27	0.34	0.27	0.25	0.32	0.28	0.23	0.34	0.28	0.23	0.36	0.29	0.26	0.33	0.26	0.24	0.32	0.29	0.24	0.32	0.29	0.24
1 000	0.34	0.27	0.24	0.35	0.26	0.25	0.32	0.26	0.24	0.30	0.26	0.22	0.31	0.26	0.21	0.34	0.26	0.25	0.31	0.24	0.23	0.29	0.27	0.23	0.29	0.27	0.23
750	0.33	0.26	0.23	0.34	0.25	0.25	0.31	0.25	0.23	0.29	0.25	0.21	0.30	0.25	0.20	0.32	0.25	0.24	0.30	0.23	0.22	0.28	0.26	0.22	0.28	0.26	0.22
500	0.31	0.25	0.21	0.32	0.24	0.23	0.29	0.24	0.22	0.28	0.24	0.20	0.27	0.23	0.19	0.31	0.24	0.22	0.28	0.22	0.21	0.27	0.25	0.21	0.27	0.25	0.21
300	0.30	0.24	0.20	0.31	0.23	0.22	0.28	0.23	0.20	0.26	0.23	0.18	0.25	0.22	0.17	0.29	0.23	0.21	0.27	0.21	0.19	0.25	0.23	0.19	0.25	0.23	0.19
100	0.28	0.22	0.17	0.29	0.20	0.19	0.26	0.20	0.18	0.24	0.21	0.16	0.24	0.20	0.15	0.27	0.20	0.18	0.24	0.18	0.16	0.22	0.21	0.17	0.22	0.21	0.17
AT START	0.21	0.16	0.13	0.22	0.15	0.14	0.20	0.16	0.13	0.18	0.15	0.11	0.18	0.15	0.11	0.20	0.13	0.12	0.17	0.12	0.11	0.16	0.14	0.10	0.16	0.14	0.10

Total efficiency of screw jack with 2-starts acme screw

η	MA 5			MA 10			MA 25			MA 50			MA 80			MA 100			MA 200			MA 350					
	RATIO			RATIO			RATIO			RATIO			RATIO			RATIO			RATIO			RATIO					
n_1 [rpm]	RV2	RN2	RL2	RV2	RN2	RL2	RV2	RN2	RL2	RV2	RN2	RL2	RV2	RN2	RL2	RV2	RN2	RL2	RV2	RN2	RL2	RV2	RN2	RL2	RV2	RN2	RL2
3 000	0.52	0.41	0.36	0.53	0.40	0.39	0.51	0.43	0.39	0.50	0.44	0.38	0.51	0.44	0.38	0.54	0.43	0.41	0.52	0.42	0.39	0.51	0.48	0.41	0.51	0.48	0.41
1 500	0.48	0.38	0.33	0.49	0.36	0.35	0.47	0.38	0.34	0.46	0.40	0.33	0.46	0.40	0.33	0.49	0.39	0.36	0.48	0.38	0.35	0.46	0.43	0.36	0.46	0.43	0.36
1 000	0.46	0.36	0.31	0.46	0.35	0.33	0.45	0.36	0.33	0.43	0.37	0.30	0.43	0.37	0.30	0.46	0.36	0.33	0.45	0.35	0.32	0.44	0.40	0.33	0.44	0.40	0.33
750	0.44	0.35	0.29	0.44	0.33	0.31	0.44	0.35	0.32	0.42	0.35	0.29	0.42	0.35	0.29	0.45	0.34	0.32	0.43	0.33	0.31	0.42	0.39	0.31	0.42	0.39	0.31
500	0.42	0.33	0.28	0.42	0.31	0.30	0.41	0.33	0.30	0.39	0.34	0.28	0.40	0.33	0.27	0.43	0.33	0.31	0.41	0.31	0.29	0.40	0.35	0.29	0.40	0.35	0.29
300	0.40	0.31	0.26	0.41	0.29	0.28	0.39	0.31	0.27	0.37	0.32	0.25	0.36	0.32	0.25	0.39	0.31	0.27	0.38	0.29	0.27	0.36	0.33	0.28	0.36	0.33	0.28
100	0.37	0.28	0.22	0.37	0.25	0.24	0.35	0.27	0.24	0.34	0.28	0.22	0.33	0.28	0.22	0.36	0.27	0.24	0.34	0.25	0.23	0.34	0.29	0.23	0.34	0.29	0.23
AT START	0.32	0.25	0.20	0.33	0.22	0.21	0.31	0.23	0.20	0.29	0.24	0.18	0.28	0.23	0.17	0.30	0.21	0.19	0.28	0.20	0.18	0.26	0.23	0.18	0.26	0.23	0.18

Screw jacks MA Series - options

Cover

The housing of the screw jacks MA Series is enclosed with two covers, one on the top and one on the bottom, available in two executions: CB (low cover) or CA (raised cover).

The raised cover CA allows the fitting of bronze guide bushes or protective tubes. The raised cover CA with toleranced outer diameter acts as a centring register of the screw jack inside the machine structure.

Screw jacks with travelling nut (Mod.B) have raised cover as standard, mounted on the screw jack housing on the opposite side of the acme screw, to protect the rotating threaded screw end.

Ordering code: **CB-CB, CB-CA, CA-CB, CA-CA**
(based on application requirements)

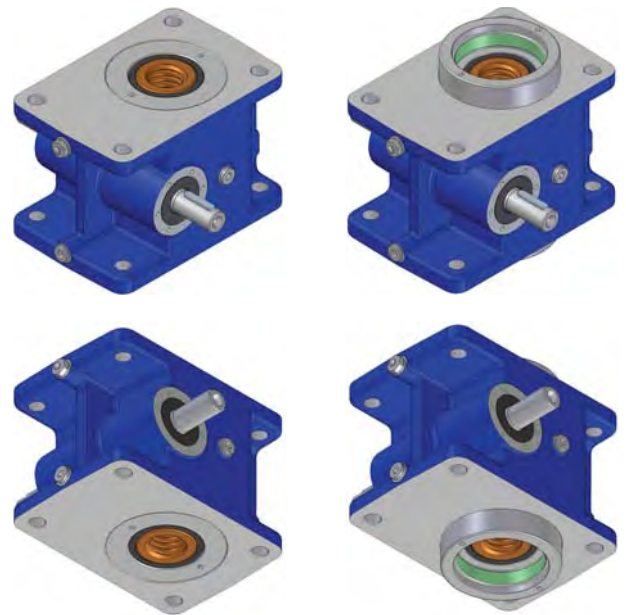

Bronze guide

Available for screw jacks with travelling screw (Mod. A) only.

The bronze guide keep the coaxial position of the acme screw with the internal thread of the worm wheel. It is mounted on the raised cover CA **on both sides** of the screw jack housing.

Bronze guides are recommended in case of even low radial load.

Ordering code: **G-G**

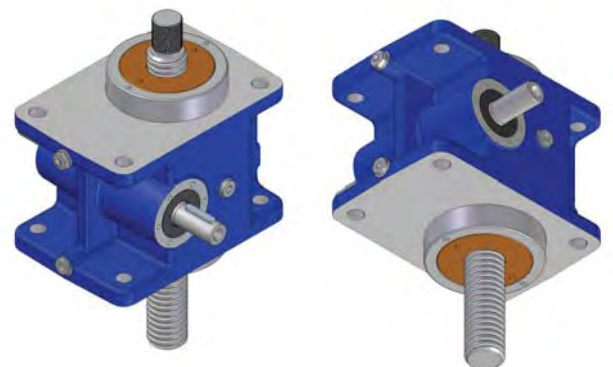

If the screw jack needs a protective tube in addition to the bronze guides, it is screwed to the bronze guide thread.

Ordering code: **G-TG**

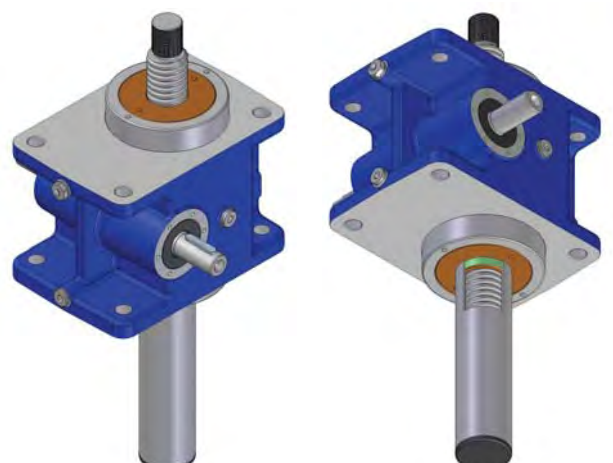

Use of bronze guides is indispensable in applications with trunnion mount!

Screw jacks MA Series - options

Stop nut

Available for screw jacks with travelling screw (Mod. A) only.

The mechanical stop prevents the acme screw thread unscrewing clear of the screw jack housing. It is a washer pinned at the acme screw end (opposite the attachment side) that blocks the screw translation when reaching the relative stop.

The acme screw length is defined to allow, under normal use, at the maximum extended position, 20 mm of additional stroke (safety extra-stroke).

If the mechanical stop reaches accidentally the relative stop, it is necessary to check the screw jacks components to verify possible damages.

Ordering code: **SN**

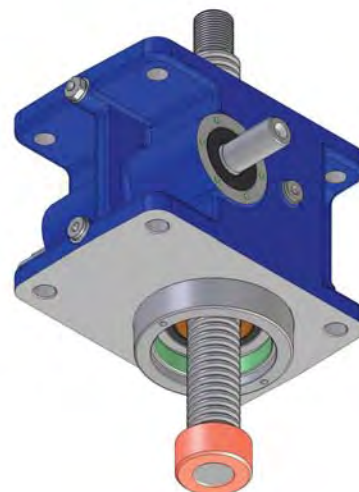

Protective tube

Available for screw jacks with travelling screw (Mod. A) only.

The protective tube is screwed in the raised cover CA and encloses the acme screw below the housing, protecting it from damages and/or environment pollution such as dust, water, etc. Furthermore, it allows the fitting of other options such as limit switches and/or anti-turn device.

Material is aluminium or steel if anti-turn device is fitted.

Ordering code: **T**

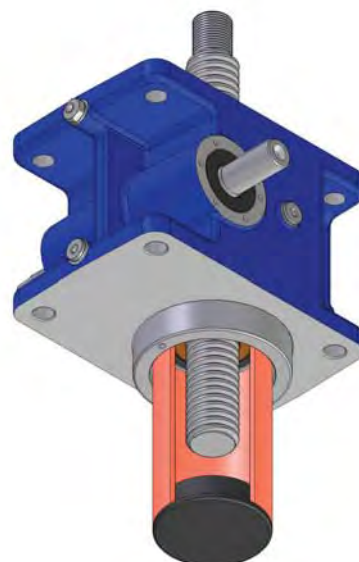

Anti-turn device

Available for screw jacks with travelling screw (Mod. A) only.

The anti-turn device is necessary when the load to be lifted may turn, i.e. the screw guidance does not prevent rotation, or in case the application does not properly allow the acme screw reaction to permit the translation.

Functioning: a steel key is fitted along the protective tube and a keyed bronze washer is fixed at the end of the acme screw; this prevents the screw rotation and forces the screw translation.

Up to screw jack size 50 (acme screw Tr 40×7) included, the anti-turn device has only one key; from size 80 (acme screw Tr 55 ×9) on, it has two keys.

The bronze bush also acts as a stop nut against acme screw unthreading.

Ordering code: **AR**

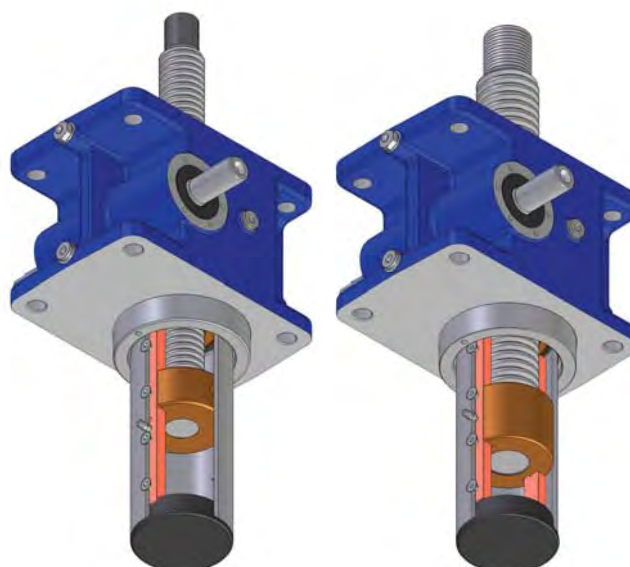

Screw jacks MA Series - options

Trunnion mount

Available for both screw jacks models: with travelling screw (Mod. A) and with travelling nut (Mod. B).

The trunnion mount bolts on to either the top or the bottom of the screw jack housing and allows pivoting of the screw jack around the axis defined by trunnion mount's lateral pins.

On screw jack Mod. A: the acme screw attachment must have a cylindrical hole with axis parallel to the trunnion mount lateral pin axis.

On screw jack Mod. B: the part of the machine where the bronze nut MB is fixed must have two lateral cylindrical pins (or holes) with axis parallel to the trunnion mount lateral pin axis.

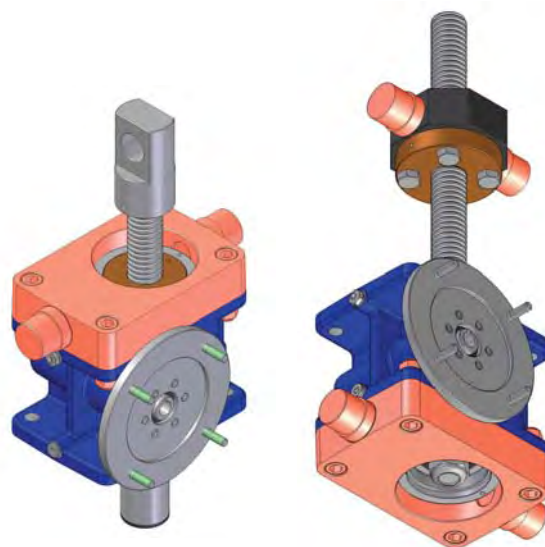
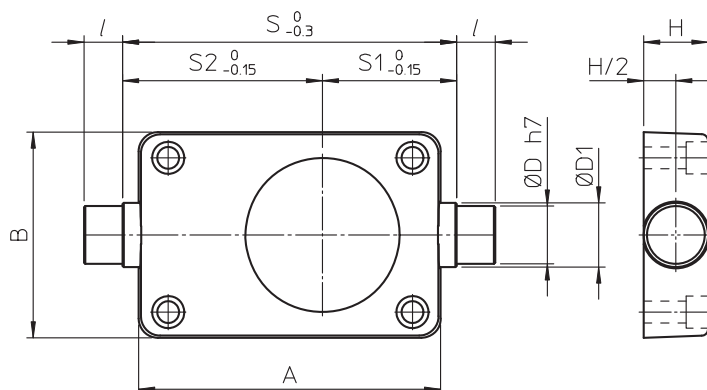

2

	MA 5	MA 10	MA 25	MA 50	MA 80	MA 100	MA 200	MA 350
A	124	140	175	235	235	276	330	415
B	80	105	130	160	160	200	230	300
ØD	15	20	25	45	45	50	70	80
ØD ₁	20	25	30	50	50	60	80	90
H	20	25	30	50	50	60	80	90
l	15	20	20	30	30	40	45	60
S	130	145	200	260	260	305	360	440
S ₁	50.5	56.5	80	104.5	104.5	119.5	132	181.5
S ₂	79.5	88.5	120	155.5	155.5	185.5	228	258.5
mass [kg]	0.8	1.6	3.2	9.8	9.8	15.8	29	52

Ordering code: **SC (TF side)**

screw jacks Mod. A
with SC fitted on side towards acme screw attachment

Ordering code: **SC (opposite TF side)**

screw jacks Mod. A
with SC fitted on side opposite to acme screw attachment

Ordering code: **SC (screw side)**

screw jacks Mod. B
with SC fitted on side towards acme screw

Ordering code: **SC (opposite screw side)**

screw jacks Mod. B
with SC fitted on side opposite to acme screw

Screw jacks MA Series - options

Bellows

Available for both screw jacks models: with travelling screw (Mod. A) and with travelling nut (Mod. B). In applications with particular environment conditions, bellows protect the screw from contaminants.

Unless otherwise required in the purchase order, bellows supplied are circular, sewn, in NYLON with a PVC outside and inside coating, suitable for industrial applications in general. For special application requirements, bellows in material suitable for use in specific environment (marine environment, food industry, environment with presence of abrasive material, ...) or in different execution (split with zip or velcro, moulded in PVC or rubber bellows, ...) could be supplied on request.

The bellows cause changes to the retracted and extended lengths and screw jack overall dimensions stated in the catalogue. On request, orders will be acknowledged with a screw jack drawing giving exact dimensions.



2

Screw jacks MA Mod.A with bellows

Usually, bellows are fitted between the acme screw attachment and worm gearbox, and at the opposite side the protection tube is fitted.

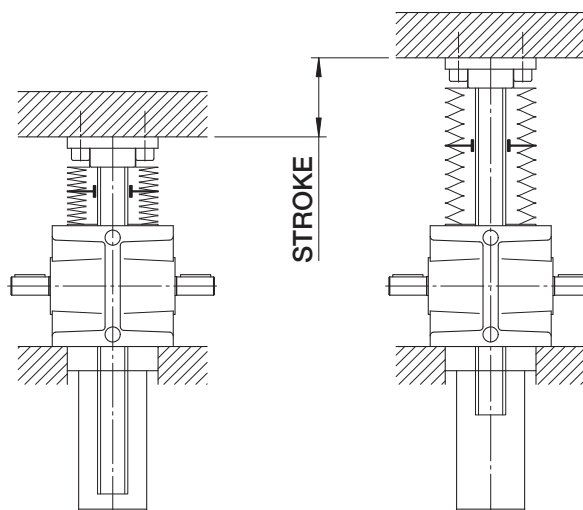

If necessary, a protective bellows can be fitted on the opposite side of the worm gearbox too.

In case the screw jack shall have a screw without attachment (with threaded end NF only), we advise to specify required end fixing dimensions (\varnothing_c , l) in the purchase order.

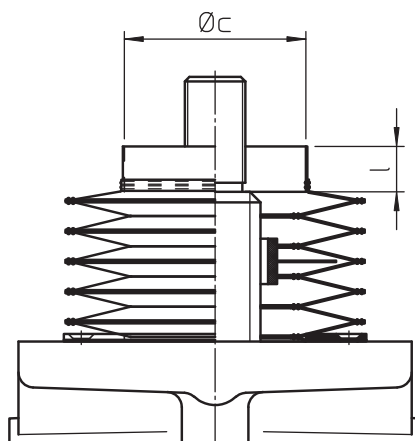

Ordering code: **B**

Screw jacks MA Series - options

Screw jacks MA Mod.B with bellows

Bellows are normally fitted between the screw jack housing and the nut and also between the nut and the acme screw end. Some applications may require bellows in only one of these two position.

The dimension of the bellows attachment between screw jack housing and bronze nut is determined by the screw jack's dimensions while the bellows attachment between bronze nut and acme screw end depends on the application structure the bellows shall fit.

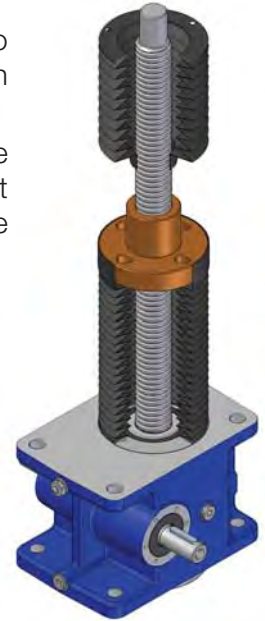

2

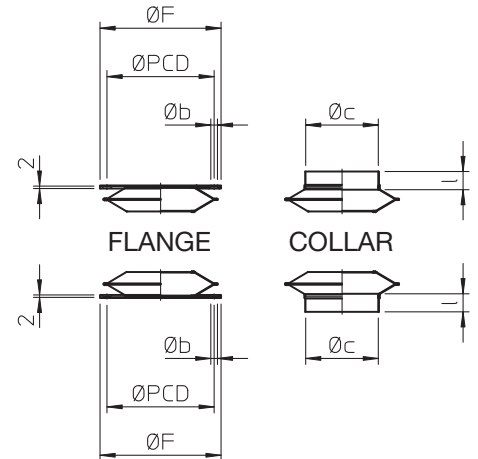
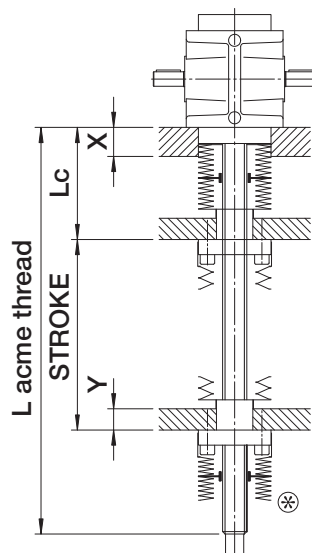
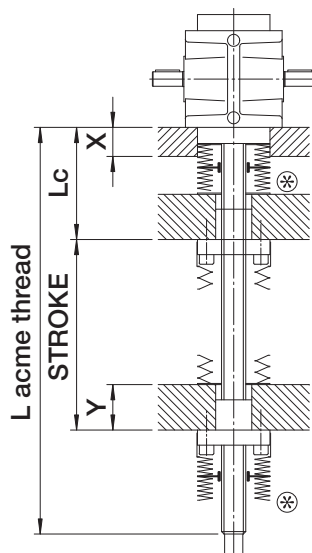
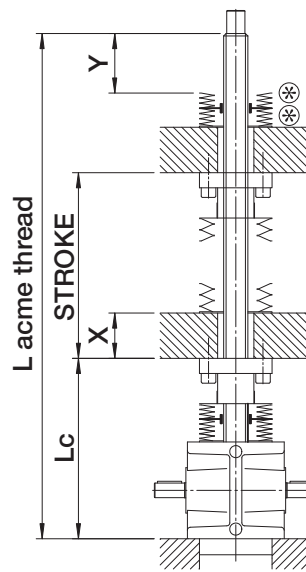
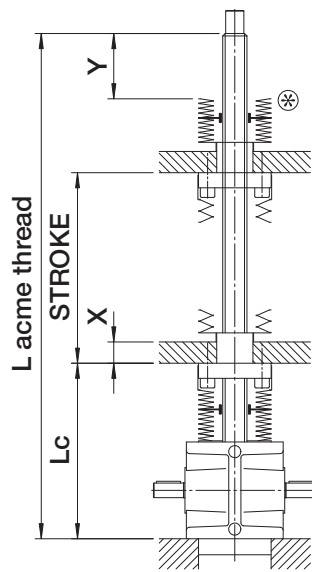
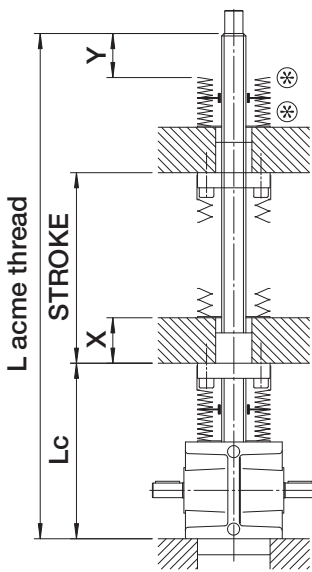
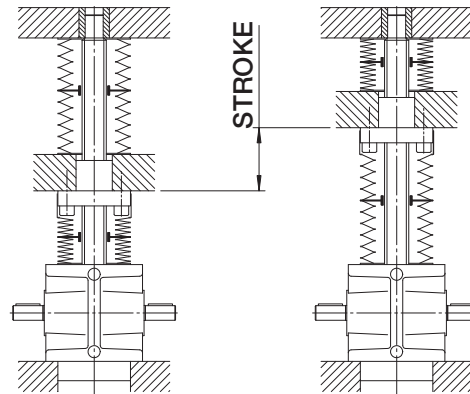

⊗ - bellows attachment dimensions to be defined

Screw jacks MA Series - options

Safety nut

Available for both screw jacks models: with travelling screw (Mod. A) and with travelling nut (Mod. B).

The safety nut is a back-up feature to prevent the load dropping in an uncontrolled manner in the event of working nut thread breaking due to overload or achieving of critical wear level (wear level that causes the breaking of the remaining thread section with normal working load only).

The safety nut is an extension to the standard nut (wormwheel inside Mod.A screw jacks or external travelling nut of Mod.B screw jacks) and changes the screw jack overall dimensions.

The safety nut works with one particular load direction only. Its position as regards the standard nut is conditioned by the load direction.

Following drawings show a screw jack with safety nut in case of acme screw subjected to push load. In case of pull load, the position of the nut would be on the opposite side of the screw jack housing (Mod. A) or of the external travelling nut (Mod. B).

By new screw jacks, the distance **b** between standard nut and safety nut is equal to the half of the profile pitch (**P**) of the acme thread.

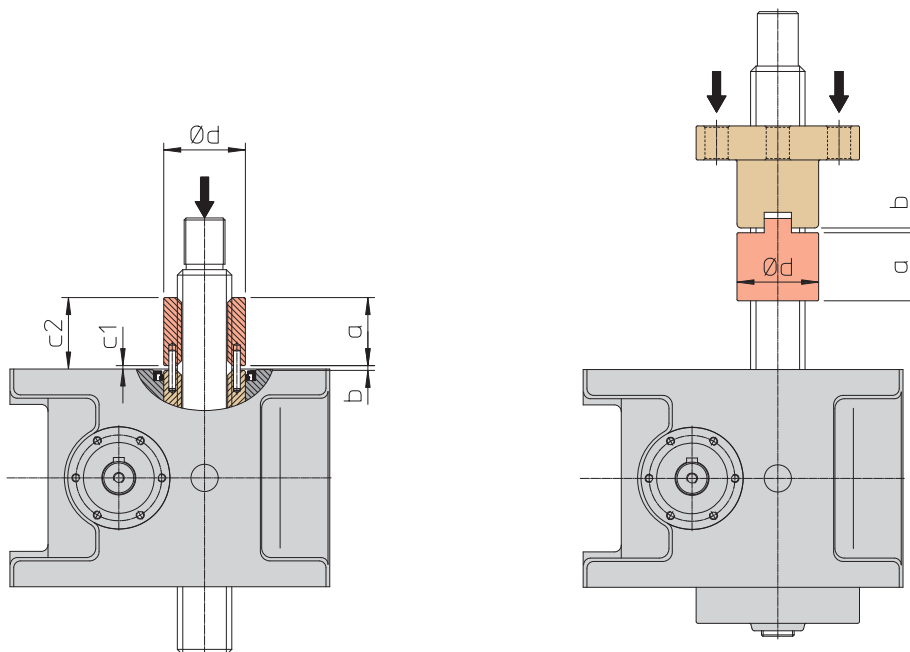

Screw jacks MA Mod.A with safety nut

	MA 5	MA 10	MA 25	MA 50	MA 80	MA 100	MA 200	MA 350
a	28	33	35	50	70	70	95	115
b	2	2.5	3	3.5	4.5	6	6	8
c ₁	1.5	2	2.5	2.5	3.5	5	5	7
c ₂	29.5	35	37.5	52.5	73.5	75	100	122
Ød	30	35	50	60	70	80	100	140

Ordering code: **MSA push** screw jacks Mod.A with safety nut for push load

Ordering code: **MSA pull** screw jacks Mod.A with safety nut for pull load

Screw jacks MA Mod.B with safety nut

	MA 5	MA 10	MA 25	MA 50	MA 80	MA 100	MA 200	MA 350
a	28	33	35	50	70	70	95	115
b	2	2.5	3	3.5	4.5	6	6	8
Ød	30	40	50	60	75	80	100	150

Ordering code: **SBC push** screw jacks Mod.B with safety nut for push load

Ordering code: **SBC pull** screw jacks Mod.B with safety nut for pull load

Screw jacks MA Series - options

Acme thread wear level check

Available for both screw jacks models: with travelling screw (Mod. A) and with travelling nut (Mod. B).

Due to working conditions (load, speed, temperature, lubrication), the thread of the working nut wears out. Some applications require the possibility to keep the current wear level under control to prevent reaching the critical wear level and consequent thread breaking by replacing the nut early.

Usually, a value equal to 1/4 of the profile pitch (**P**) of the acme thread is considered as max. wear level admitted.

With thread wear, the distance **b** between working nut and safety nut (see drawings on previous page) reduces to the working nut. By measuring this change, it is possible to get the current wear level of the thread.

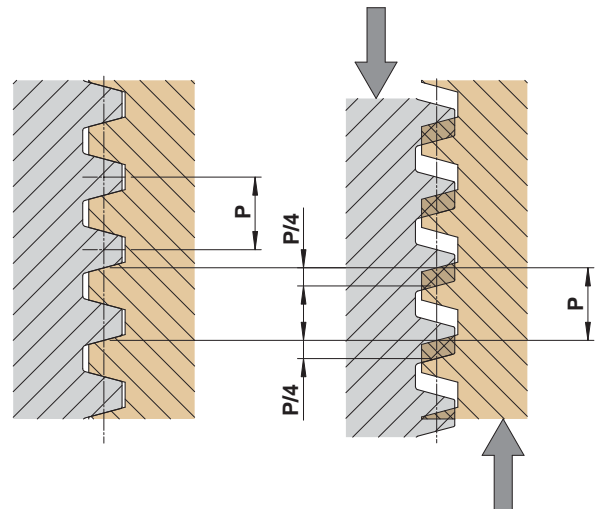

Following drawings show the possible solutions:

- check of dimension **c₁**, **c₂**, **c₃** or **c₄** for screw jacks with travelling screw (Mod. A) or of distance **b** for screw jacks with travelling nut (Mod. B) - see drawings on previous page and below - comparing the current value with the initial one (with new screw jack),
- appliance of an electric switch (see drawings below) which is activated when the pre-established wear level is reached giving an electric signal.

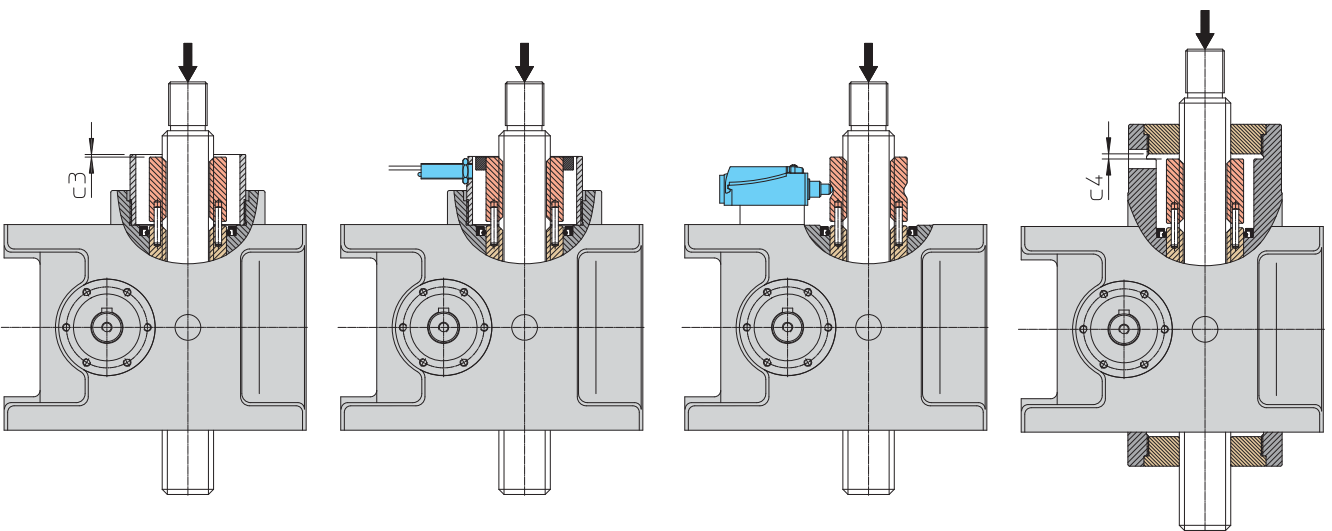

Thread wear control on screw jacks MA Series Mod.A

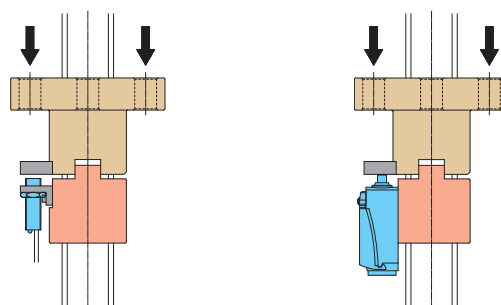

Thread wear control on screw jacks MA Series Mod.B

Screw jacks MA Series - options

Wormwheel rotation detector

Available for both screw jacks models: with travelling screw (Mod. A) and with travelling nut (Mod. B).

Some applications require the possibility to verify if the wormwheel rotates while the worm shaft is moving in order to get information about the good condition and functioning of the wormwheel tootinging.

Functioning on screw jacks with travelling screw (Mod.A): usually, this device is required for applications where a safety nut is already present. A “crown” of empty and full spaces (created by machining the safety nut end, see picture on the right), while rotating, activates a corresponding proximity switch. As output of such proximity switch, activated and deactivated by the alternation of empty and full spaces, a “train” of impulses is generated and it confirms the rotation of the wormwheel. On the contrary, the constant output signal of the proximity means the stop of the wormwheel.

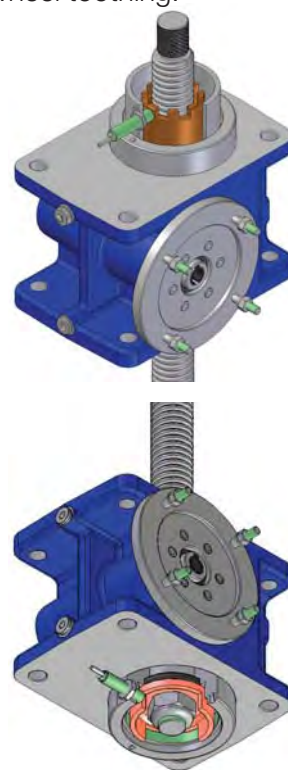

Functioning on screw jacks with travelling nut (Mod. B): on the opposite side of the acme screw, a cylindrical element, machined in order to have a “crown” of empty and full spaces (see picture on the right), is fixed to the wormwheel. While rotating, it activates and deactivates a corresponding proximity switch. As output of such proximity switch, activated and deactivated by the alternation of empty and full spaces, a “train” of impulses is generated and it confirms the rotation of the wormwheel. On the contrary, the constant output signal of the proximity means the stop of the helical wormwheel.

Magnetic stroke end switches

Available for screw jacks with travelling screw (Mod. A) and for size 5, 10 o 25. Not compatible with anti-turn device AR.

Functioning: the magnetic stroke end switches are sensors with reed contact and are fixed with a clamp on the protective tube T, made in aluminium or other non-magnetic metal. They are activated by the magnetic field generated by a magnetic ring fitted on the acme screw end.

In case the screw jack is not stopped after the sensor activation, without magnetic field the sensor restores the original state. In case the limit switches are used to stop the screw jack, we recommend to provide for an electric connection in order to latch the signal and to prevent that the screw jack moves again in the same direction.

Screw jacks with magnetic limit switches are supplied with two sensors for the acme screw extreme positions. On request, extra switches for intermediate distances can be supplied.

The position of the sensors along the tube is adjustable.

SENSOR FEATURES		
Switching output	reed	
Contact	normally CLOSED	normally OPEN
Supply voltage	(5 ... 120) V ac/dc	(5 ... 230) V ac/dc
Voltage drop	≤ 3.5 V	
Corrente continuativa	≤ 100 mA ac	
Switching capacity	≤ 6 W	
Connection	cable, 2 × 0.12 mm ² , length 2 m	

Ordering code: **FCM-NC** for screw jacks with normally closed magnetic switches FCM
 Ordering code: **FCM-NO** for screw jacks with normally open magnetic switches FCM



Screw jacks MA Series - options

Inductive proximity stroke end switches

Available for screw jacks with travelling screw (Mod.A) only.

Functioning: proximity limit switches are PNP inductive sensors with normally CLOSED contact (NC) fitted on the protective tube and activated by the metallic ring fixed on the acme screw end.

In case the screw jack is not stopped after the sensor activation, when the metallic ring moves away the sensor restores the original state (becomes deactivated). In case the limit switches are used to stop the screw jack, we recommend to provide for an electric connection in order to latch the signal and to prevent that the screw jack moves again in the same direction.

Screw jacks with proximity limit switches are supplied with two sensors for the acme screw extreme positions. Extra switches for intermediate distances available on request.

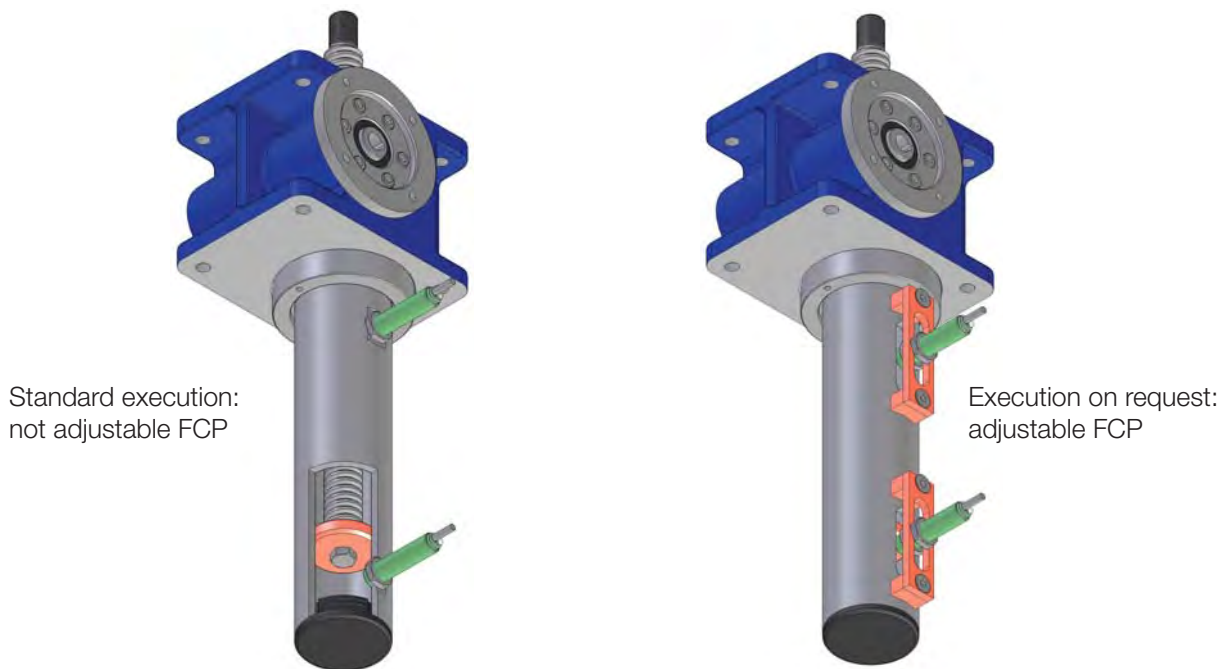

On standard execution, the sensors position along the tube is not adjustable and is not angularly fixed. On request, it can be supplied with angular position at customer's indication.

Execution with axial adjustment of the sensors position available on request.

Technical details:

Type:	inductive, PNP
Contact:	normally CLOSED (NC)
Voltage range:	(10 ... 30) Vdc
Max. output current:	200 mA
Voltage drop (activated sensor):	< 1.8 V
Wires:	3 × 0.2 mm ²
Cable length:	2 m

Ordering code: **standard FCP (not adjustable)**
adjustable FCP

Adjustable backlash

Available for both screw jacks models: with travelling screw (Mod.A) and with travelling nut (Mod.B).

The adjustment of the axial backlash in the acme thread is a feature recommended for applications where load acts in both directions and/or there are vibrations. It can be obtained by using of adjustable backlash device RMG, which reduces axial backlash between acme screw and bronze nut allowing high positioning precision. With the RMG device it is also possible to compensate the wear of the nut thread.

On screw jacks with travelling screw (Mod. A), the working nut (the helical wormwheel inside the housing) is split in two halves (see picture on the right). By screwing the adjustment cover (after the release of the locking screw), the two halves of the wormwheel close in until the axial backlash is set to zero. The thread of one of the two halves of the wormwheel will touch one flank of the acme screw thread, while the thread of the other half will touch the opposite flank.

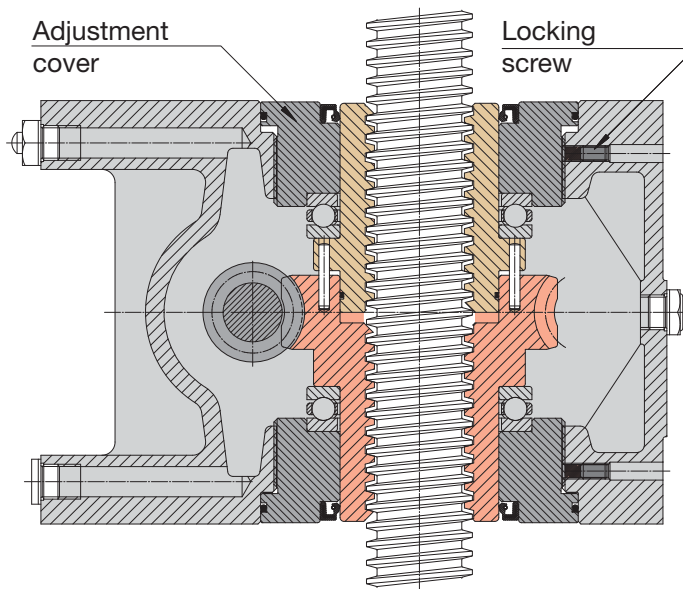

Both nuts work in a perfectly symmetric way, therefore the load capacity for both push or pull load is the same and is equivalent to the nominal capacity.

On screw jacks with travelling nut (Mod. B), the RMG device is made by two nuts (main nut and secondary nut, see picture on the right). It allows to adjust the axial backlash, but not to work with maximum load capacity in both directions. We recommend to carefully evaluate the mounting position to make the main nut work in the prevailing load condition.

In any case, please contact SERVOMECH Engineering Dpt. for proper and suitable evaluations.

By screwing the adjustment screws the two nuts close in and, as a consequence, the acme thread of one of the two nuts will near one side of the acme screw thread, while the thread of the other will near the opposite side of the acme screw. In this way the axial backlash will be reduced as required.

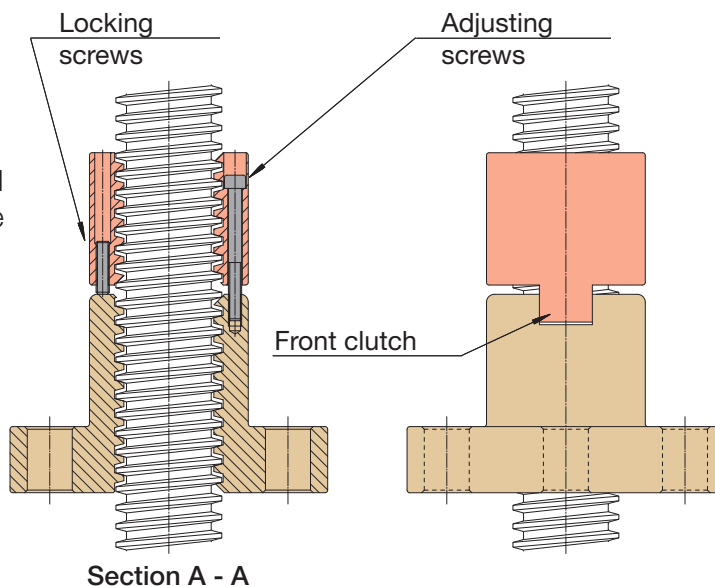

The torque transmission from the second nut to the main nut is given by the front clutch between the two nuts.

An excessive backlash reduction can reduce screw jack efficiency. For further details, please contact SERVOMECH Engineering Dpt.

Codice: **RMG**

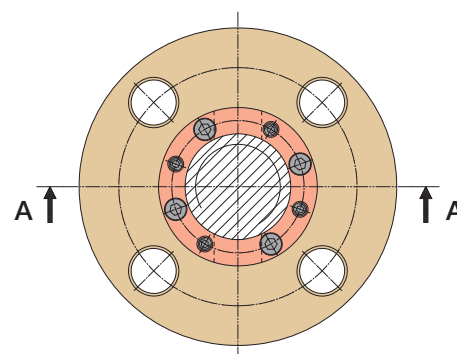

Screw jacks MA Series - options

Material: stainless steel

For applications in particular environment conditions or in food industry, the screw jacks MA Series can be supplied with stainless steel acme screw and/or screw attachment on request. Available steels: AISI 303, AISI 304, AISI 316.

Ordering code: **TR inox** stainless steel acme screw for screw jacks Mod. A or Mod. B

Ordering code: **P inox** stainless steel flange end P, for screw jacks Mod. A

Ordering code: **TF inox** stainless steel rod end TF, for screw jacks Mod. A

IEC Motor connection

		MA 5	MA 10	MA 25	MA 50	MA 80	MA 100	MA 200	MA 350
63	B5	F	F	F					
	B14	F	F						
71	B5	B	B	F	F	F			
	B14	B	B	F					
80	B5			B	F	F	F		
	B14			B					
90	B5			B	B	B	F	F	
	B14			B	B	B			
100 - 112	B5				B	B	B	F	
	B14				B	B	B		
132	B5							B	B
160	B5								B

F - plug-in IEC flange and hollow shaft

B - bell-housing + coupling IEC

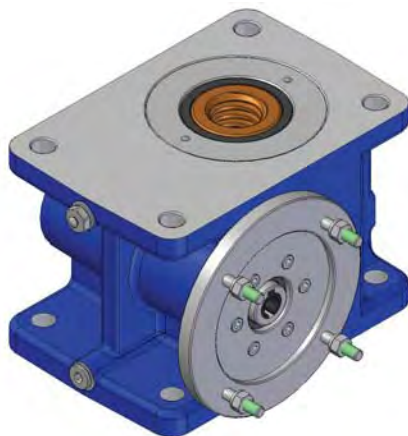

Flange or bell-housing at drawing for hydraulic motors or servomotors connection available on request.

Screw jacks MA Series - coding description

Screw jacks MA Series with travelling screw (Mod.A)

MA	50	Mod.A	RL1	Vers. 3 (80 B5)	U-RH	C300							
1	2	3	4	5	6	7							
TF	B	G	CA	MSA	/	RMG	/	CA	G	SC	T	AR	FCP
8													
...													
9													
...													
10													
AC 3-phase brake motor 0.75 kW 4 poles 230/400 V 50 Hz IP 55 Isol. F													
11													

1 MA (screw jack MA Series)

2 Screw jack size

5 ... 350

page 20 - 21, 24 - 25, 28, 31

3 Mod.A (Model: travelling screw)

4 Ratio and number of acme screw starts

page 20 - 21, 24 - 25, 28, 31

5 Input versions

Vers.1, Vers.2, Vers.3, Vers.4, Vers.5, Vers.6

page 7

6 Screw jack mounting and input shaft position

U-RH, U-LH, D-RH, D-LH, H-RH, H-LH

page 7

7 Screw jack stroke length (ex.: C300 = 300 mm stroke)

8 Options

NF, P, TF, N	Screw end	page 34 - 35
B	Bellows	page 40
SC	Trunnion mount	page 39
G	Bronze guide	page 37
CB, CA	Low cover, raised cover	page 37
RMG	Adjustable backlash	page 46
SN	Stop nut	page 38
T	Protective tube	page 38
AR	Anti-turn device	page 38
FCM-NC	Magnetic stroke end switches (normally closed)	page 44
FCP-NC	Proximity stroke end switches (PNP, normally closed)	page 45

9 Other options

example: encoder (with all relevant data)

10 Further specifications

example: stainless steel acme screw AISI 303
example: low temperature lubricant

11 Motor specifications

12 Coding form

page 49

13 Application sketch

Screw jacks MA Series - coding description

Screw jacks MA Series with travelling screw (Mod.A)

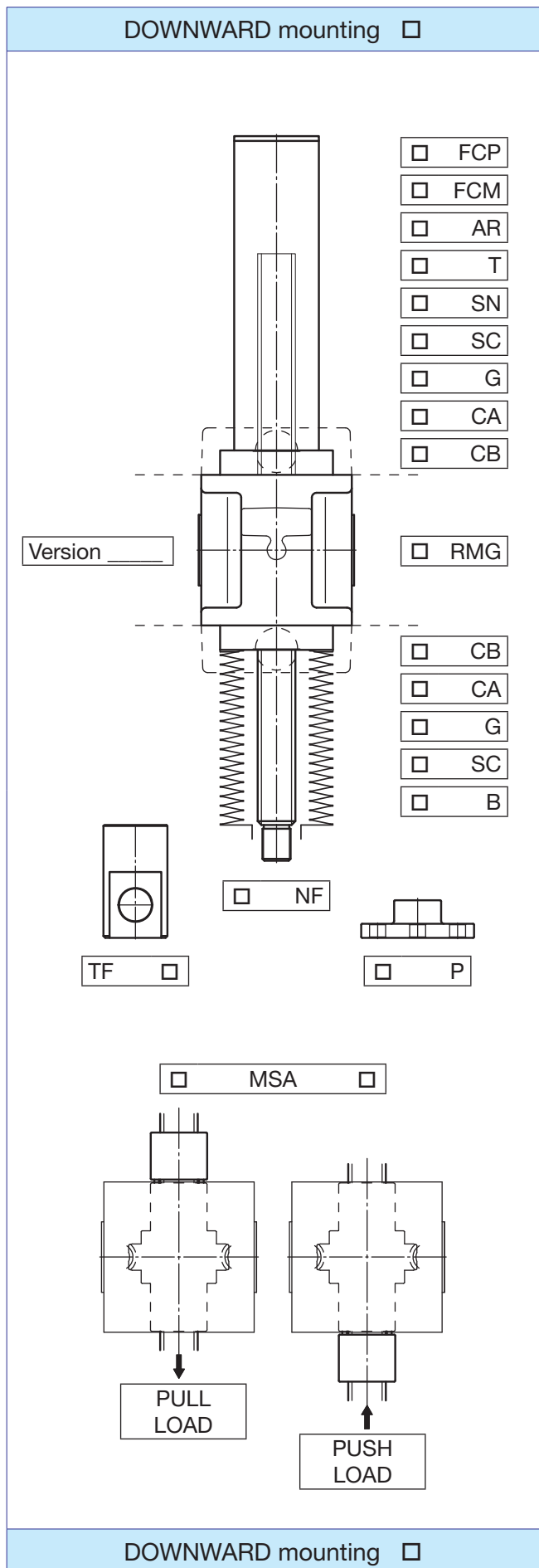
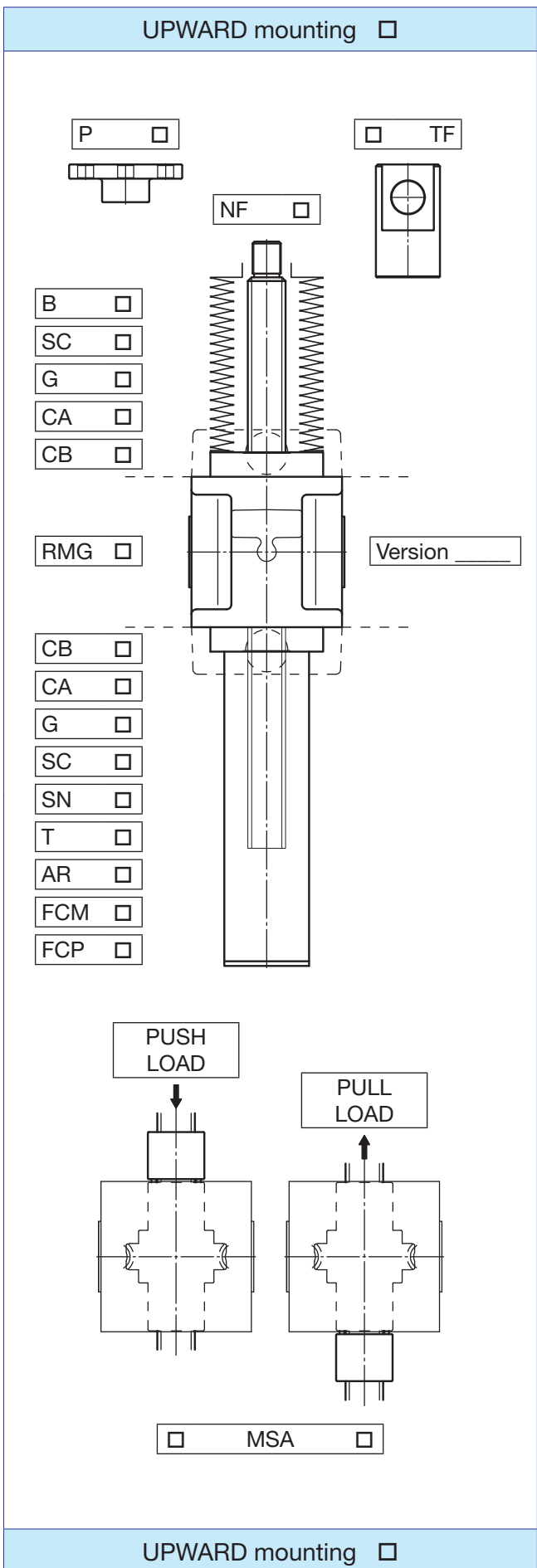

2

Screw jacks MA Series - coding description

Screw jacks MA Series with travelling nut (Mod.B)

MA	50	Mod.B	RL1	Vers. 3 (80 B5)	U-RH	C300
1	2	3	4	5	6	7
N	B2	MB+SBC	B1	CB	/	CA
8						
...						
9						
...						
10						
AC 3-phase brake motor 0.75 kW 4 poles 230/400 V 50 Hz IP 55 Isol. F						
11						

1 MA (screw jack MA Series)

2 Screw jack size

5 ... 350

page 20 - 21, 24 - 25, 28, 31

3 Mod.B (Model: travelling nut)

4 Ratio and number of acme screw starts

page 20 - 21, 24 - 25, 28, 31

5 Input versions

Vers.1, Vers.2, Vers.3, Vers.4, Vers.5, Vers.6

page 7

6 Screw jack mounting and input shaft position

U-RH, U-LH, D-RH, D-LH, H-RH, H-LH

page 7

7 Screw jack stroke length (ex.: C300 = 300 mm stroke)

8 Options

N Screw end

page 34 - 35

B₁, B₂ Bellows

page 41

MB Working nut

page 34 - 35

SBC Safety nut

page 42

RMG Adjustable backlash

page 46

CB, CA Low cover, raised cover

page 37

9 Other options

example: encoder (with all relevant data)

10 Further specifications

example: stainless steel acme screw AISI 303

example: low temperature lubricant

11 Motor specifications

12 Coding form

page 51

13 Application sketch

Screw jacks MA Series - coding description

Screw jacks MA Series with travelling nut (Mod.B)

UPWARD mounting

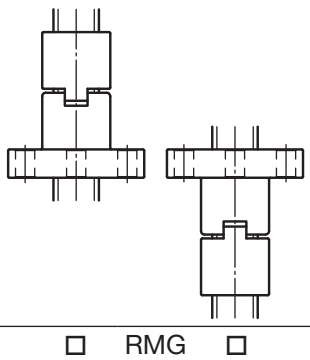

RMG

MB+SBC **MB** **MB+SBC**

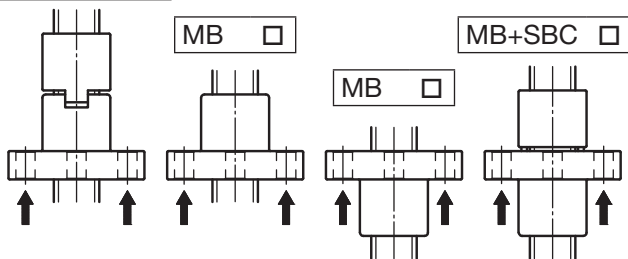

PULL LOAD

PUSH LOAD

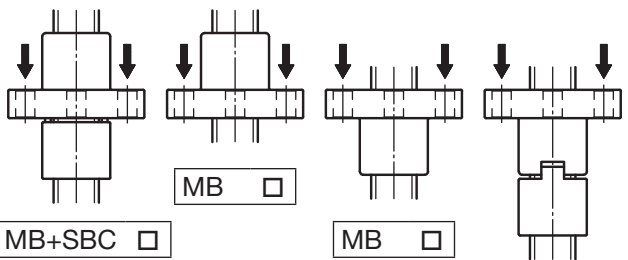

MB+SBC **MB** **MB+SBC**

N **B2**

B1 **CA** **CB**

Version _____

CB **CA**

UPWARD mounting

DOWNWARD mounting

CA CB

Version _____

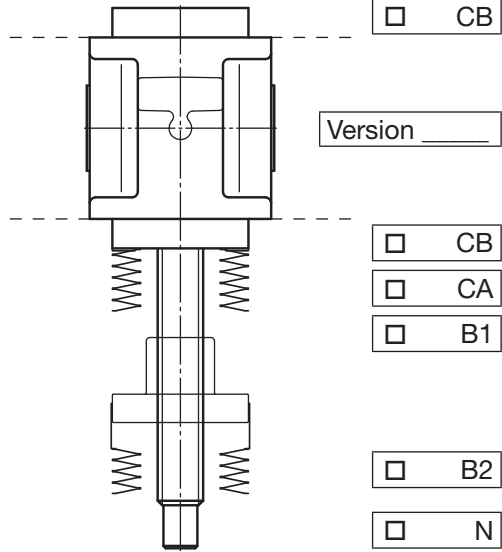

CB CA B1

B2 N

MB+SBC **MB** **MB+SBC**

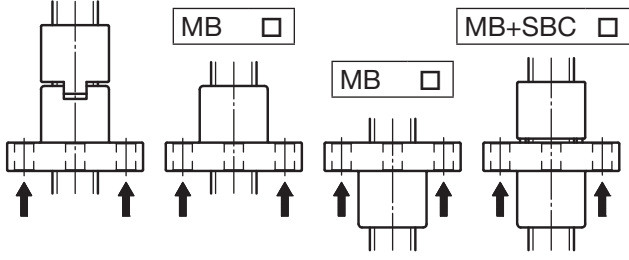

PUSH LOAD

PULL LOAD

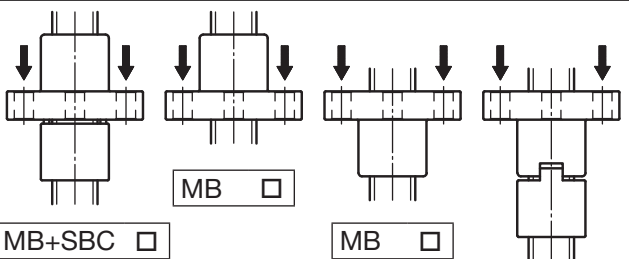

MB+SBC **MB** **MB+SBC**

RMG

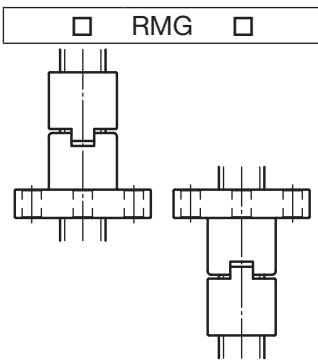

DOWNWARD mounting

Screw jacks MA Series

Screw jacks MA Series with travelling screw (Mod. A) - spare parts

2

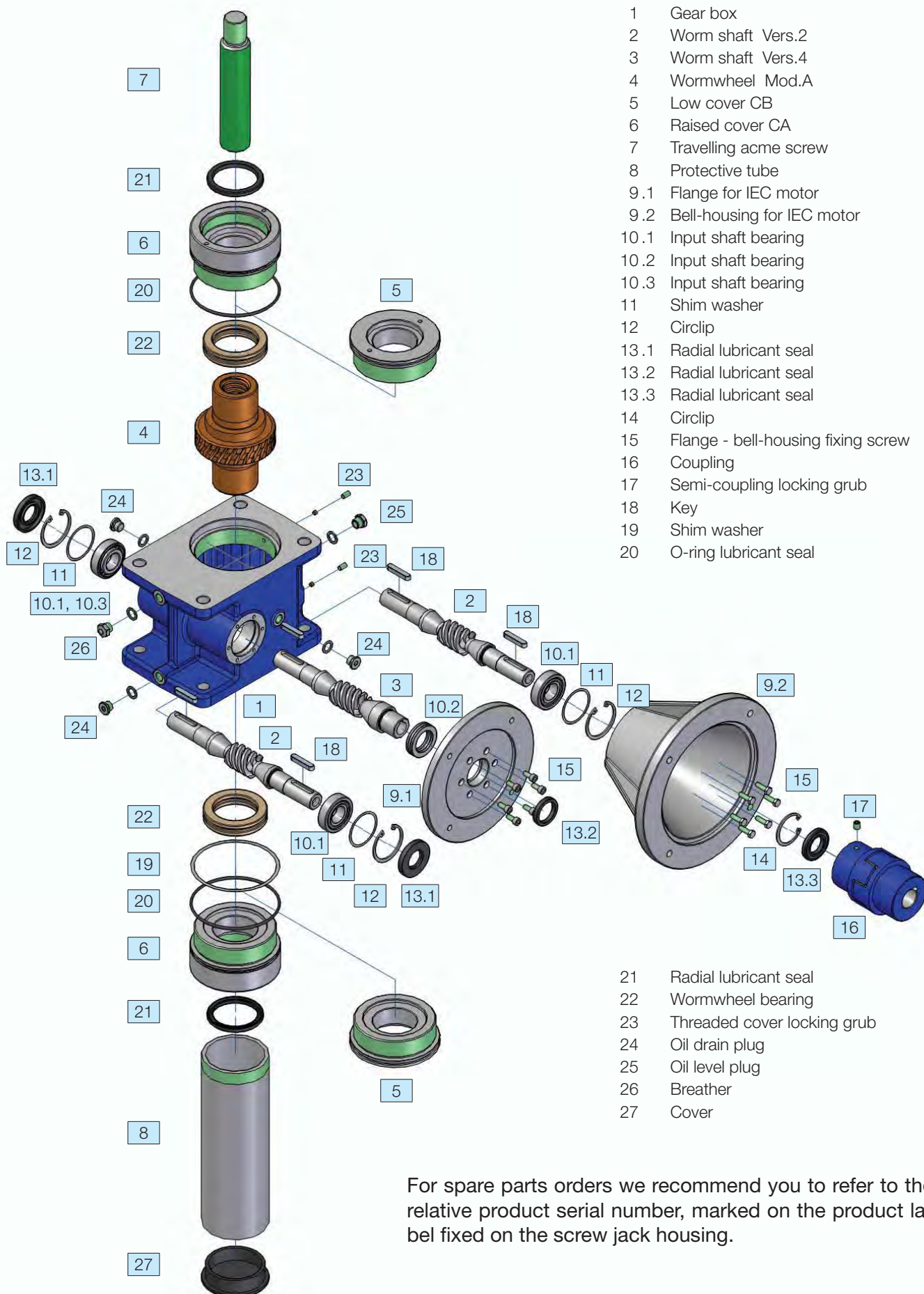

- 1 Gear box
- 2 Worm shaft Vers.2
- 3 Worm shaft Vers.4
- 4 Wormwheel Mod.A
- 5 Low cover CB
- 6 Raised cover CA
- 7 Travelling acme screw
- 8 Protective tube
- 9.1 Flange for IEC motor
- 9.2 Bell-housing for IEC motor
- 10.1 Input shaft bearing
- 10.2 Input shaft bearing
- 10.3 Input shaft bearing
- 11 Shim washer
- 12 Circlip
- 13.1 Radial lubricant seal
- 13.2 Radial lubricant seal
- 13.3 Radial lubricant seal
- 14 Circlip
- 15 Flange - bell-housing fixing screw
- 16 Coupling
- 17 Semi-coupling locking grub
- 18 Key
- 19 Shim washer
- 20 O-ring lubricant seal

- 21 Radial lubricant seal
- 22 Wormwheel bearing
- 23 Threaded cover locking grub
- 24 Oil drain plug
- 25 Oil level plug
- 26 Breather
- 27 Cover

For spare parts orders we recommend you to refer to the relative product serial number, marked on the product label fixed on the screw jack housing.

Screw jacks MA Series

Screw jacks MA Series with travelling nut (Mod. B) - spare parts

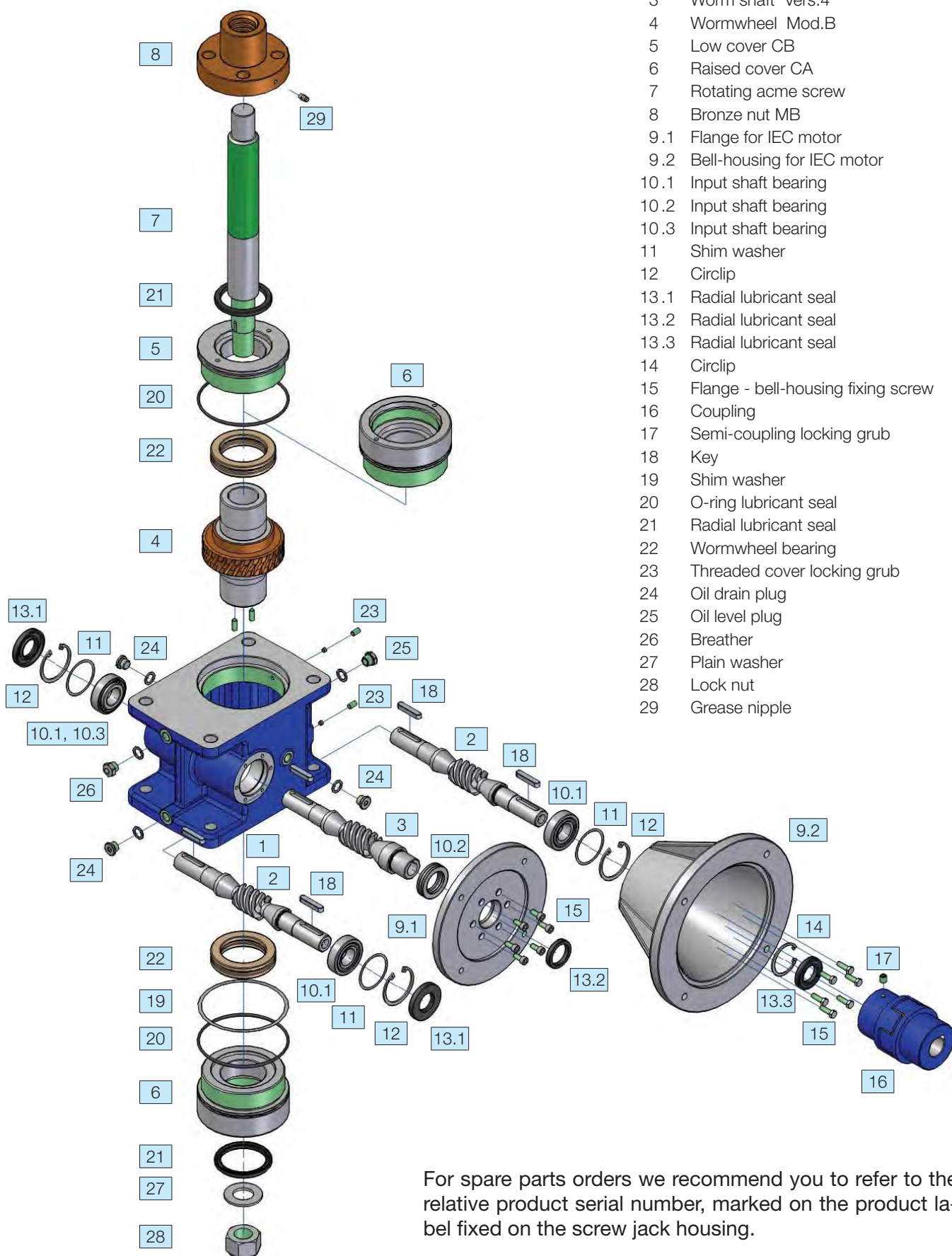

- 1 Gear box
- 2 Worm shaft Vers.2
- 3 Worm shaft Vers.4
- 4 Wormwheel Mod.B
- 5 Low cover CB
- 6 Raised cover CA
- 7 Rotating acme screw
- 8 Bronze nut MB
- 9.1 Flange for IEC motor
- 9.2 Bell-housing for IEC motor
- 10.1 Input shaft bearing
- 10.2 Input shaft bearing
- 10.3 Input shaft bearing
- 11 Shim washer
- 12 Circlip
- 13.1 Radial lubricant seal
- 13.2 Radial lubricant seal
- 13.3 Radial lubricant seal
- 14 Circlip
- 15 Flange - bell-housing fixing screw
- 16 Coupling
- 17 Semi-coupling locking grub
- 18 Key
- 19 Shim washer
- 20 O-ring lubricant seal
- 21 Radial lubricant seal
- 22 Wormwheel bearing
- 23 Threaded cover locking grub
- 24 Oil drain plug
- 25 Oil level plug
- 26 Breather
- 27 Plain washer
- 28 Lock nut
- 29 Grease nipple

2

For spare parts orders we recommend you to refer to the relative product serial number, marked on the product label fixed on the screw jack housing.